



SANTA FE METROPOLITAN PLANNING ORGANIZATION  
**DESIGNING FOR SAFER CYCLING:**  
INFRASTRUCTURE SOLUTIONS FOR SANTA FE'S  
ROAD NETWORK

### What's Inside:

1. Background Goals & Purpose
2. Maintenance Goals & Responsibilities
3. Best Practices & Peer City Examples
4. Facility Design Strategies



# TABLE OF CONTENTS

<b>EXECUTIVE SUMMARY</b> .....	<b>4</b>
<b>Introduction + Purpose</b> .....	<b>4</b>
<b>Overview</b> .....	<b>4</b>
<b>Findings</b> .....	<b>6</b>
<i>Safety Concerns and Barriers to Ridership</i> .....	6
<i>Community Demand and Public Perception</i> .....	6
<i>Economic and Environmental Impacts</i> .....	6
<i>Equity and Accessibility</i> .....	6
<i>Maintenance and Long-Term Sustainability</i> .....	6
<b>Recommendations</b> .....	<b>6</b>
<i>Infrastructure Improvements</i> .....	6
<i>Key Recommendations Include:</i> .....	8
<i>Facility Type Selection Matrix</i> .....	9
<b>GLOSSARY</b> .....	<b>10</b>
<b>INTRODUCTION</b> .....	<b>12</b>
<b>Background</b> .....	<b>12</b>
<b>Goal</b> .....	<b>12</b>
<b>Purpose</b> .....	<b>12</b>
<b>Existing Bike Planning</b> .....	<b>12</b>
<i>Santa Fe 2020-2045 Metropolitan Transportation Plan</i> .....	13
<i>Santa Fe Metropolitan Bicycle Master Plan 2019</i> .....	13
<i>Santa Fe Bicycle Design Toolkit</i> .....	14
<i>Multimodal Transition Plan</i> .....	14
<i>Local Road Safety Plan 2022</i> .....	15
<i>Safe Routes to School Action Plan 2024-2027</i> .....	15
<i>Pop-Up Protected Bike Lanes Report</i> .....	16
<i>Pedestrian Master Plan 2015</i> .....	16
<i>Santa Fe Metropolitan Public Transit Master Plan 2015</i> .....	17
<i>Santa Fe Midtown Master Plan</i> .....	17
<b>MAINTENANCE</b> .....	<b>21</b>
<b>Best Practices for Maintenance</b> .....	<b>21</b>

<i>Vegetation</i> .....	22
<i>Snow</i> .....	22
<i>Surface Treatment</i> .....	22
<i>Drainage Grates</i> .....	22
<i>Monitoring</i> .....	23
<b>Peer City Maintenance Examples</b> .....	<b>24</b>
<i>Proactive Maintenance Planning</i> .....	24
<i>Specialized Equipment</i> .....	24
<i>Public Reporting Systems</i> .....	25
<i>Dedicated Funding</i> .....	26
<b>INTERSECTION CONFLICTS</b> .....	<b>27</b>
<b>Best Practices</b> .....	<b>27</b>
<i>Pavement Markings</i> .....	27
<i>Raised Crossings</i> .....	27
<i>Narrow or Eliminate Driveways</i> .....	28
<i>Visibility and Sightlines</i> .....	28
<i>Tight Turning Radii</i> .....	28
<i>Protected Intersections</i> .....	28
<i>Right-of-Way Enforcement and Education</i> .....	28
<b>Peer City Examples</b> .....	<b>29</b>
<i>Albuquerque, New Mexico</i> .....	29
<i>Tucson, Arizona</i> .....	29
<i>Raton, New Mexico</i> .....	29
<i>Portland, Oregon</i> .....	29
<i>Cambridge, Massachusetts</i> .....	30
<i>Boulder, Colorado</i> .....	30
<i>Flagstaff, Arizona</i> .....	31
<b>FACILITY DESIGN</b> .....	<b>32</b>
<b>Basic Considerations</b> .....	<b>32</b>
<b>Bike Lane Surface</b> .....	<b>32</b>
<b>Type of Bicycle Facilities</b> .....	<b>33</b>
<b>Facility Orientation</b> .....	<b>34</b>

<i>One-way</i> .....	34
<i>Two-way</i> .....	34
<i>Median</i> .....	34
<i>Center</i> .....	34
<b>Curbs Adjacent to Bike Lanes</b> .....	<b>35</b>
<i>Sloping Curbs</i> .....	35
<i>Mountable Curbs</i> .....	35
<i>Vertical Curbs</i> .....	35
<b>Facility Options</b> .....	<b>36</b>
<b>Painted Buffer</b> .....	<b>38</b>
<b>Conclusion</b> .....	<b>40</b>
<b>RECOMMENDATIONS</b> .....	<b>41</b>
<b>Vertical Posts</b> .....	<b>42</b>
<i>Vertical Posts Design Strategies</i> .....	44
<i>Vertical Posts Design Elements</i> .....	46
<i>Thermoplastic Paint</i> .....	46
<i>Vertical Post</i> .....	46
<i>Painted Bike Lane</i> .....	47
<b>On-Street Parking</b> .....	<b>48</b>
<i>On-Street Parking Design Strategies</i> .....	50
<i>On-Street Parking Design Elements</i> .....	52
<i>Thermoplastic Paint Buffer</i> .....	52
<i>Parking Lane</i> .....	52
<i>Painted Bike Lane</i> .....	53
<b>Curb Stops</b> .....	<b>54</b>
<i>Curb Stops Design Strategies</i> .....	56
<i>Curb Stops Design Elements</i> .....	58
<i>Continuous Curb</i> .....	58
<i>Curb Stop</i> .....	58
<i>Painted Bike Lane</i> .....	59
<b>Planters</b> .....	<b>60</b>

<i>Planters Design Strategies</i> .....	62
<i>Planters Design Elements</i> .....	64
<i>Thermoplastic Paint</i> .....	64
<i>Planters</i> .....	64
<i>Painted Bike Lane</i> .....	65
<b>Raised Median</b> .....	<b>66</b>
<i>Raised Median Design Strategies</i> .....	68
<i>Raised Median Design Elements</i> .....	70
<i>Continuous Curb</i> .....	70
<i>Raised Median</i> .....	70
<i>Painted Bike Lane</i> .....	71
<b>Raised Bike Lane</b> .....	<b>72</b>
<i>Raised Bike Lane Design Strategies</i> .....	74
<i>Raised Bike Lane Design Elements</i> .....	76
<i>Buffer From Street</i> .....	76
<i>Raised Lane</i> .....	76
<i>Painted Bike Lane</i> .....	77
<b>When Should A Safer Bicycle Facility Be Prioritized ...</b>	<b>78</b>
<b>Facility Type Selection Matrix</b> .....	<b>79</b>
<b>Conflict Resolution</b> .....	<b>81</b>
<i>Intersections and Driveways</i> .....	81
<i>Bus Stops and Transit Stations</i> .....	81
<i>Parking and Loading Zones</i> .....	81
<b>DESIGN STRATEGIES</b> .....	<b>82</b>
<b>Unique Bicycle Facilities Design Elements</b> .....	<b>83</b>
<b>Landscape Buffers</b> .....	<b>84</b>
<b>Materials</b> .....	<b>86</b>
<b>Paint and patterns</b> .....	<b>88</b>

# EXECUTIVE SUMMARY

## INTRODUCTION + PURPOSE

Designing for Safer Cycling serves as an amendment to the 2019 Bicycle Master Plan. Its primary goal is to evaluate opportunities and constraints for implementing safer bicycle infrastructure tailored to Santa Fe’s unique conditions. By addressing safety concerns—identified as a primary barrier to increased bike usage—the amendment aims to promote cycling as a viable and attractive transportation option while supporting Santa Fe’s equity, climate, and quality-of-life goals.

## OVERVIEW

Designing for Safer Cycling evaluates bicycle infrastructure options to address Santa Fe’s unique road network and safety challenges. Building on previous plans, such as the 2019 Bicycle Master Plan, the amendment provides recommendations for creating safer and more accessible bicycle facilities that support an all ages and abilities bicycle network.

**The plan provides recommendations for creating safer and more accessible bike facilities that align with the city’s sustainability, equity, and quality-of-life goals.**

Public outreach and local data highlight safety concerns—particularly conflicts with vehicle traffic and limited bicycle infrastructure—as the primary barriers to increased cycling. National Best Practices and case studies demonstrate that separated bike lanes can significantly reduce crashes and encourage cycling among “interested but concerned” riders.

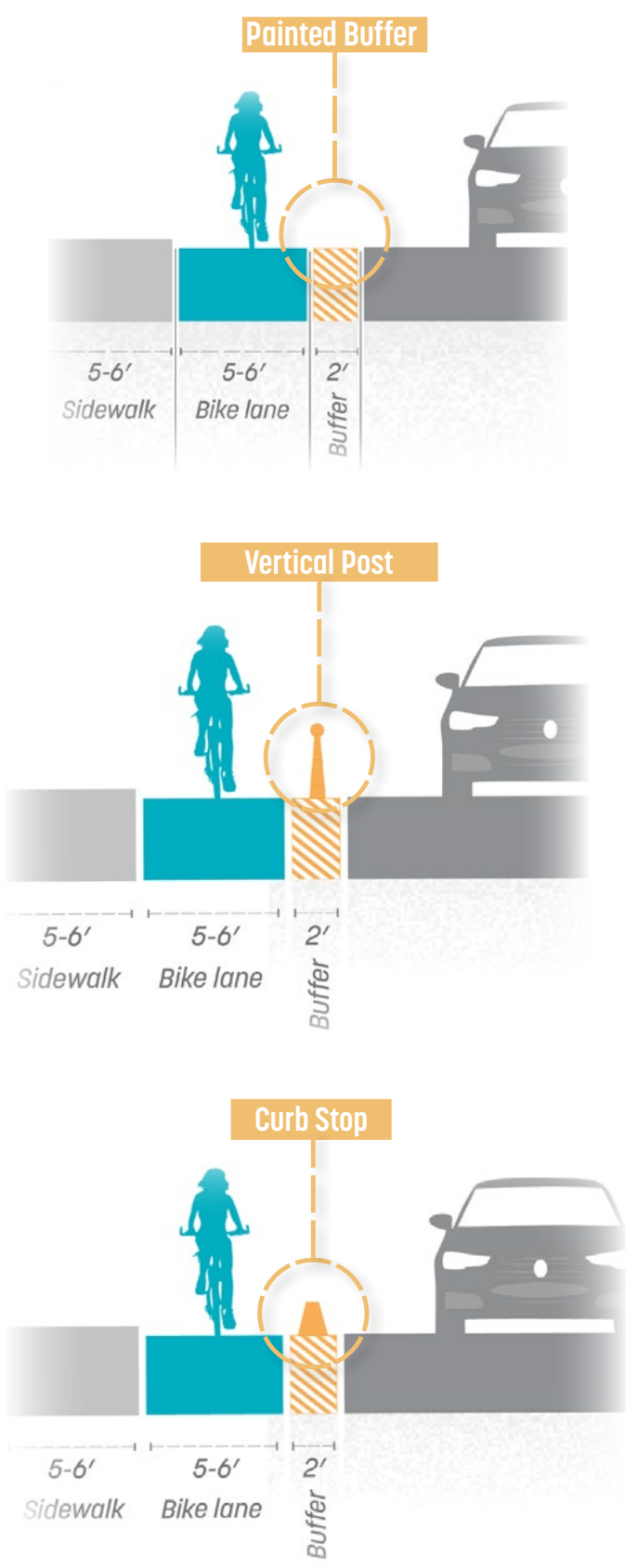

The plan outlines a range of facility options that balance cost, effectiveness, and local conditions. **Painted buffers** offer a quick, low-cost solution by providing visual separation, but they lack physical barriers and require frequent maintenance. **Vertical Posts** or bollards provide moderate protection and visibility at a reasonable cost but need regular replacement, particularly in areas with snow removal impacts. **Curb stops**, made from concrete or modular materials, offer long-lasting physical barriers with minimal maintenance, although they have higher installation costs and may affect drainage.

For greater protection and visual enhancement, **planters and raised medians** serve as effective solutions. Planters provide both physical separation and aesthetic benefits, supporting green infrastructure but requiring ongoing maintenance. **Raised medians**, on the other hand, offer robust, continuous protection and contribute to traffic calming with more infrequent maintenance—though they come with higher upfront costs. **Raised bike lanes**, which elevate cyclists off the street or to sidewalk level, provide the highest level of safety and visibility but are more challenging to implement on existing narrow roadways. **On-street parking** as a buffer is another cost-effective solution that uses parked cars to create separation while maintaining existing parking spaces.

The plan recommends a **prioritization matrix** (“*Facility Priority Matrix*” on page 78) that considers vehicle speeds, traffic volumes, and right-of-way constraints to determine the most appropriate facility type for each corridor.

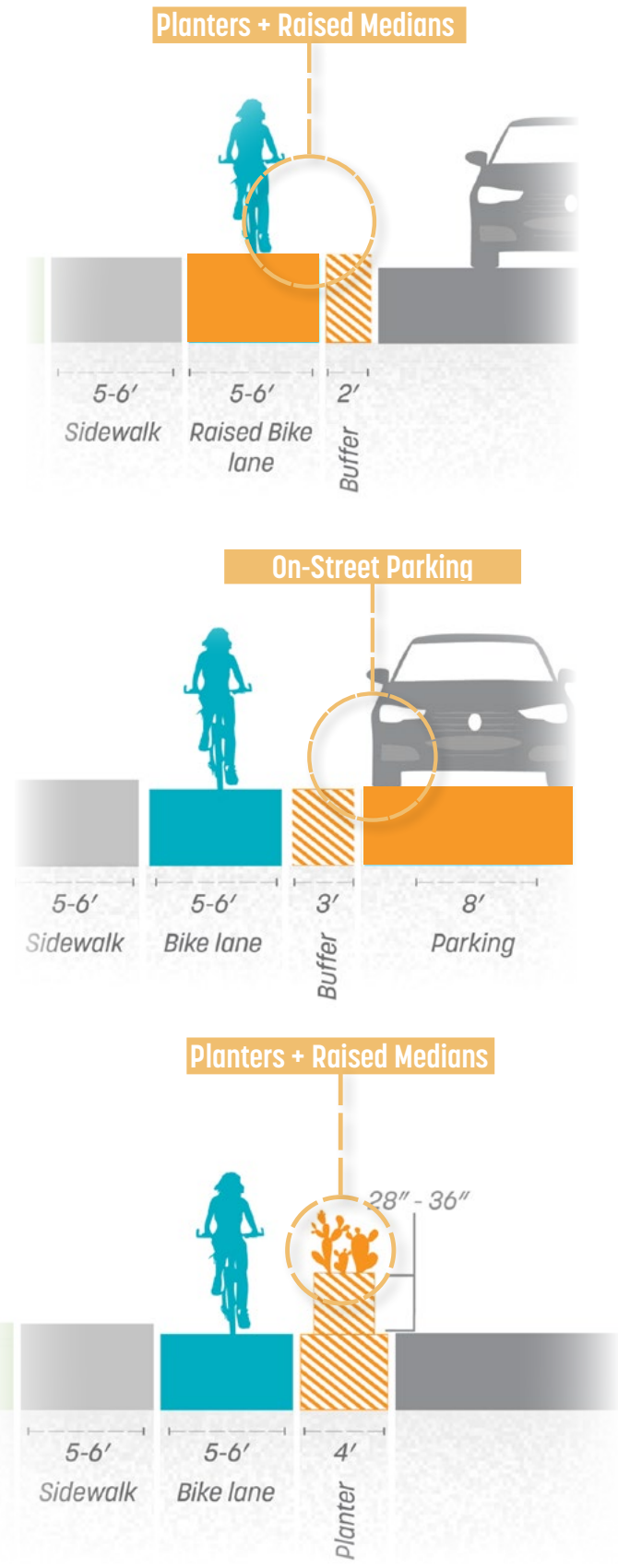

## FINDINGS

The plan's findings underscore the necessity of safer, better-maintained bicycle infrastructure.

### Safety Concerns and Barriers to Ridership

**Safety is consistently identified as the primary barrier to increased bicycle use in Santa Fe.** Between 2010 and 2022, 397 bicycle-related crashes were recorded, many due to insufficient separation between cyclists and motor vehicles. **Traditional bike lanes, which rely solely on painted lines for delineation, fail to provide adequate protection.** Sideswipe collisions and dooring incidents highlight the limitations of existing facilities.

Research and case studies from peer cities reveal that protected bike lanes significantly improve safety. **When cities increase the density of protected lanes, fatal and severe crashes decrease by up to 53%.** The physical separation provided by these lanes also has a traffic-calming effect, reducing vehicle speeds and creating safer conditions for all road users.

### Community Demand and Public Perception

**Surveys and public outreach consistently show strong support for protected bike infrastructure.** A majority of respondents cite safety concerns, lack of bike paths, and discomfort near moving vehicles as reasons for not cycling more frequently. Women and families, in particular, are more likely to bike when protected lanes are available, highlighting the need for inclusive infrastructure that serves diverse community needs.

### Economic and Environmental Impacts

Protected bike infrastructure delivers measurable economic benefits. **Improved bicycle facilities attract local business patronage, boost property values, and reduce employer costs** associated with parking and employee health. Retailers benefit from increased accessibility, as cyclists tend to shop more frequently than drivers.

On the environmental front, **reducing car dependence through better bike facilities aligns with Santa Fe's carbon neutrality goal for 2040.** Transportation is the largest source of greenhouse gas emissions in the city, and shifting trips from cars to bikes offers a low-cost, high-impact strategy to address climate change.

### Equity and Accessibility

Transportation and housing costs disproportionately impact low-income households, with car ownership being a significant financial burden. **In Santa Fe, 33% of the population earns less than 200% of the federal poverty level, and minority communities face heightened risks of traffic-related injuries and fatalities.** For example, American Indian residents are 11.3 times more likely to be involved in fatal crashes compared to white residents. Safer bicycle infrastructure offers these communities affordable, reliable transportation options while improving safety and accessibility.

### Maintenance and Long-Term Sustainability

Maintenance is critical to ensuring the longevity and functionality of bike facilities. Issues such as debris accumulation, inadequate snow removal, and surface degradation reduce the usability of bike lanes, deterring potential riders. The lack of a proactive maintenance plan exacerbates these challenges, underscoring the need for dedicated funding and specialized equipment.

## RECOMMENDATIONS

The plan provides a comprehensive set of recommendations focused on appropriate facility type, infrastructure design, and maintenance.

### Infrastructure Improvements

**The plan prioritizes the installation of protected and separated bike lanes using flexible delineators, curb stops, raised medians, and planters.** These facilities provide varying levels of physical separation, tailored to the needs of different streets and neighborhoods. Raised

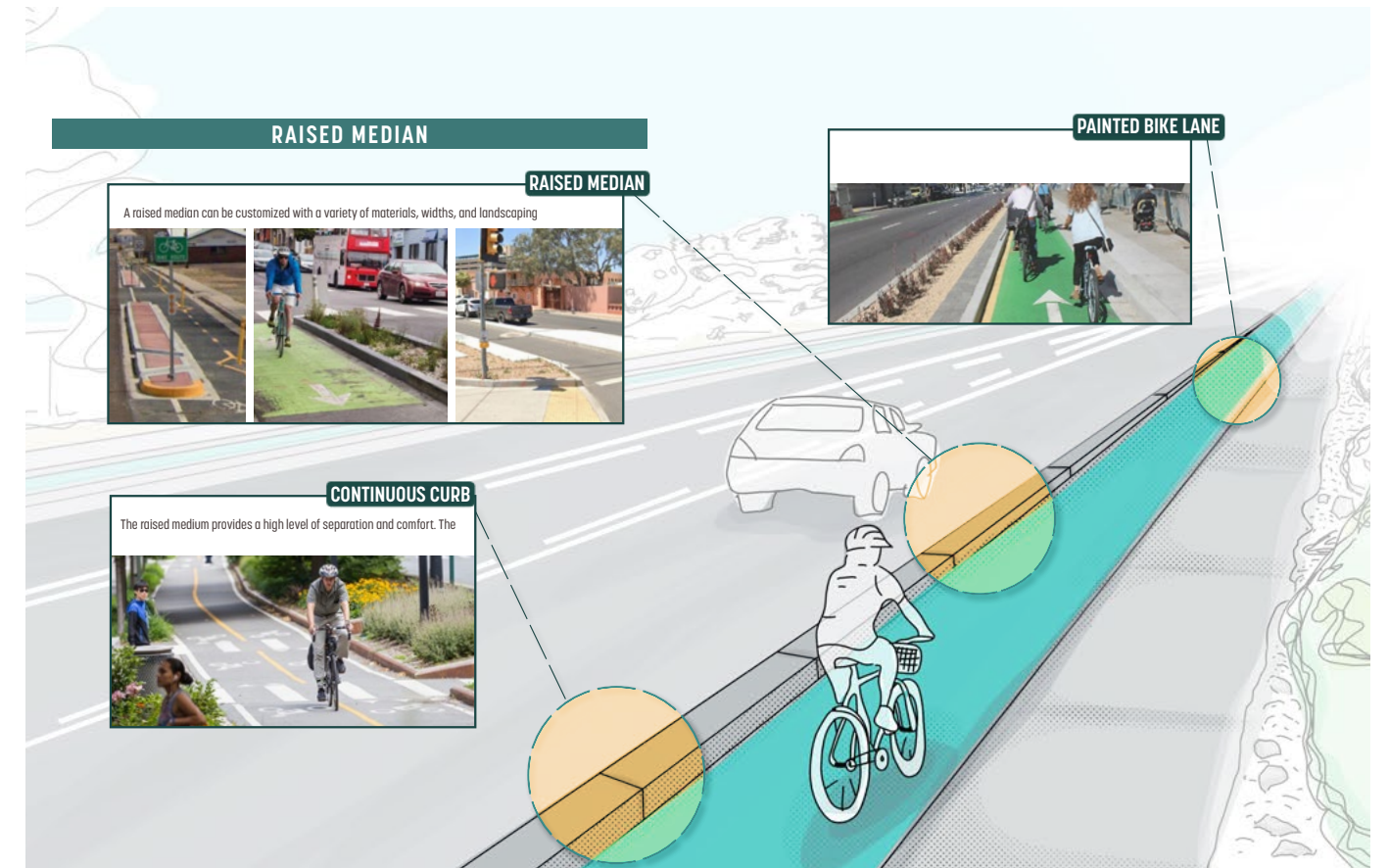

bike lanes, multi-use paths, and protected intersections are recommended to minimize cyclist-vehicle conflicts and create safer crossings.

The plan also emphasizes the need for context-sensitive design. For example, center-running bike lanes may be more suitable for streets with frequent curbside conflicts, while off-street infrastructure can provide stress-free routes for recreational and commuter cyclists alike.

**Key Recommendations Include:**

- ✓ **Painted Buffers:** Quick, low-cost visual separation but no physical barrier.
- ✓ **Vertical Posts:** Moderate protection, visible, and cost-effective but requires frequent replacement.
- ✓ **Curb Stops:** Durable, modular physical barriers with minimal maintenance.
- ✓ **On-Street Parking as a Buffer:** Cost-effective solution using parked cars for protection.
- ✓ **Planters:** Strong physical separation with aesthetic benefits but requires maintenance.
- ✓ **Raised Medians:** Robust, continuous protection that enhances traffic calming.
- ✓ **Raised Bike Lanes:** Maximum safety and visibility with significant upfront costs.

The plan includes examples using existing Santa Fe roadways to illustrate potential improvements. The Yucca Street illustration to the left demonstrates how different buffers can be added to enhance cyclist protection.

By implementing these strategies and adhering to national design guidance such as AASHTO, NACTO, and FHWA, and MUTCD standards, **Santa Fe can improve cyclist safety,**

**reduce vehicle conflicts, and create a more bicycle-friendly city.** These efforts will encourage ridership, support climate goals, and enhance the urban environment for all road users.

**By implementing these strategies and adhering to national design guidance such as AASHTO, NACTO, FHWA, and MUTCD standards, Santa Fe can improve cyclist safety, reduce vehicle conflicts, and create a more bicycle-friendly city.**

The Facility Type Selection Matrix and prioritization guidelines help determine which infrastructure options are best suited for different corridors, balancing safety needs with available resources and space constraints. The plan emphasizes conflict mitigation at driveways, intersections, and transit stops, where thoughtful design—such as tight turning radii, elevated bike lanes, and staggered stop lines—can significantly reduce cyclist-vehicle interactions.

Additionally, the plan stresses the **importance of public engagement and data-driven planning to inform decisions and measure success.** Tools like pop-up protected bike lanes can test infrastructure solutions while gathering feedback from the community to refine permanent installations.

The evaluated infrastructure types reduce vehicle conflicts, encourage more people to bike, and support Santa Fe’s broader goals, including climate neutrality, economic growth, and equitable access to transportation options.

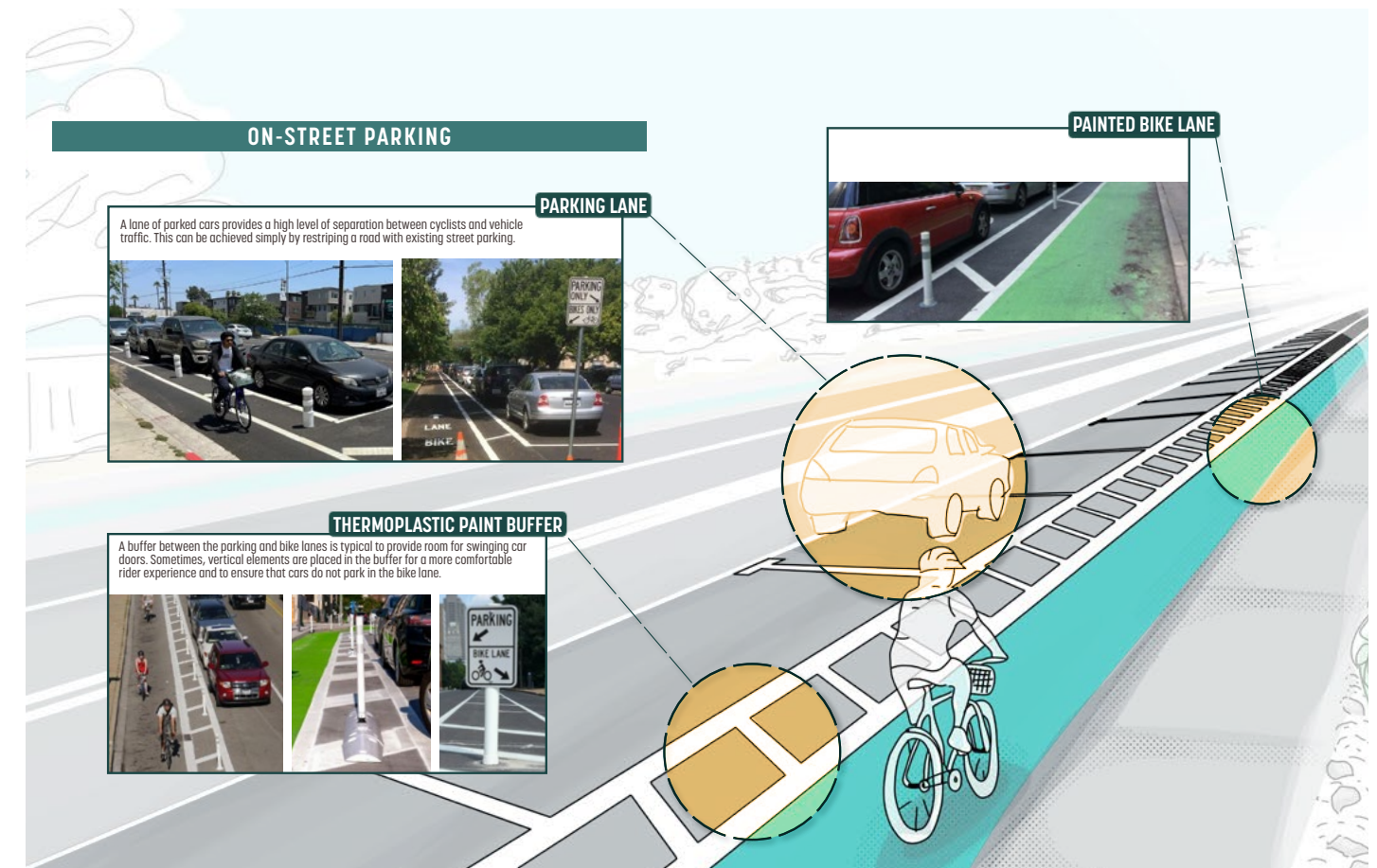

**Facility Type Selection Matrix**

	Flex Posts	Bollards	On-Street Parking	Planters	Curb Stops	Raised Median	Raised Lane
<b>Roadway Type</b>							
Major Arterial (6 Lane)						✓	✓
Minor Arterial (4 Lane)	✓					✓	✓
Minor Arterial (2 Lane)	✓	✓	✓			✓	
Collector	✓	✓	✓	✓	✓		
<b>Average Daily Traffic (ADT) *Only appropriate on roads with speed limits of 25mph or below</b>							
7k - 10k	✓	✓	*	✓			
Greater than 10k					✓	✓	✓
<b>Posted Speed (Miles per Hour)</b>							
>25 mph	✓	✓					
25-35 mph	✓	✓		✓	✓		
>35 mph						✓	✓
<b>Recommended widths for one-way facilities on both sides of the street (lane + buffer).</b>							
12'8" (one-way, on both sides of street)						✓	
14' (one-way, on both sides of street)	✓	✓				✓	✓
16' (one-way, on both sides of street)	✓	✓	✓			✓	✓
18' (one-way, on both sides of street)	✓	✓	✓	✓		✓	✓

	Flex Posts	Bollards	On-Street Parking	Planters	Curb Stops	Raised Median	Raised Lane
<b>Recommended widths for a two-way, one-side street facility (lane + buffer).</b>							
13'4" (two way, on one sides of street)							✓
14'	✓	✓				✓	✓
15'	✓	✓	✓			✓	✓
16'	✓	✓	✓	✓	✓	✓	✓
<b>Context Classification from Comp Plan?</b>							
Rural	✓					✓	✓
Rural Town	✓	✓				✓	✓
Suburban	✓	✓	✓	✓	✓	✓	✓
Urban	✓	✓	✓	✓	✓	✓	✓
Santa Fe Core		✓	✓	✓	✓		✓
<b>Comfort</b>							
Lower comfort near high vehicle travel speeds.	✓		✓	✓	✓		
Moderate comfort due to higher separation from traffic.		✓	✓	✓	✓		

# GLOSSARY

**AASHTO (American Association of State Highway and Transportation Officials)** - AASHTO guidelines guide the design, construction, operation, and maintenance of transportation infrastructure across the U.S. Developed based on engineering best practices, research, and safety considerations, these guidelines ensure consistency and reliability in transportation projects. AASHTO guidelines are widely used by government agencies and the private sector to promote safe and efficient roadway design. State DOTs must adhere to them for highway projects, while local governments apply them to streets, bike lanes, and sidewalks. At the federal level, the FHWA uses AASHTO guidelines to set funding requirements and technical assistance programs for national transportation initiatives.

**Bicycle Design Toolkit** - A set of guidelines included in planning documents, offering best practices for designing bicycle facilities, such as separated and buffered bike lanes.

**Buffer Zone** - The space between a bike lane and vehicle traffic or parked cars, designed to reduce the likelihood of collisions or encroachment.

**Curb Cuts** - Sections of the curb lowered to provide access for driveways, typically where vehicles cross bike lanes, which can pose safety concerns for cyclists. Also found at intersections that allow pedestrians, particularly those in wheel chairs, to cross at street level.

**FHWA (Federal Highway Administration)** - A U.S. government agency that oversees highway and transportation safety, providing guidance on infrastructure design, including bike lanes and pedestrian facilities.

**Green Pavement** - Colored pavement, typically green, used to highlight bike lanes at intersections and driveways, improving visibility for both cyclists and drivers.

**Multimodal Network** - An interconnected transportation network that includes various forms of transportation, such as walking, cycling, public transit, and driving, to ensure ease of movement for all users.

**NACTO (National Association of City Transportation Officials)** - NACTO develops design guidelines and best practices for urban streets, bike infrastructure, and multimodal transportation. Unlike AASHTO, which focuses on highways and statewide projects, NACTO guidelines prioritize city streets, active transportation, and transit-friendly design to create safer, more livable urban environments. NACTO's guides—such as the Urban Bikeway Design Guide and Transit Street Design Guide—are widely used by cities, transportation planners, and engineers to implement protected bike lanes, pedestrian-friendly streets, and transit-priority corridors. Many municipalities adopt NACTO guidelines to promote innovative, context-sensitive solutions that improve safety and mobility for all road users.

**Painted Buffer** - Also known as striped buffers, these are designated spaces marked with striped lines that separate cyclists from vehicle traffic or parked cars, offering an added layer of safety but no physical barrier.

**Pop-Up Protected Bike Lanes** - Temporary bike lanes with physical barriers (such as bollards or planters) installed to test the impact of protected infrastructure on cyclist safety and traffic patterns

**Protected/Separated Bike Lanes** - Bike lanes physically separated from motor vehicle traffic, using barriers such as bollards, curbs, planters, or parked cars, enhancing safety by reducing collision risks.

**Public Transit Master Plan** - A strategic document outlining improvements to public transit services, including better integration with pedestrian and bicycle infrastructure.

**Raised Bike Lane** - A bike lane physically separated and elevated from the street, often at the same height as the sidewalk, to provide maximum cyclist safety.

**Raised Crossing** - A bike lane design feature where the crossing is elevated to the height of the sidewalk, slowing vehicles and increasing cyclist visibility.

**Raised Median** - A continuous, elevated barrier separating bike lanes from vehicle lanes, offering cyclists greater safety and serving as a physical divider in the roadway.

**Right to Proceed** - Right to proceed, also known as the right of way, refers to the legal right of a vehicle, bicycle, or pedestrian to proceed first at an intersection or conflict point.

**Right-of-Way (ROW)** - Right-of-Way refers to the legal right, established through an easement, ordinance, or other legal means, to pass through or use a particular path or area of land. Having an adequate amount of legally designated land width to accommodate current and future infrastructure needs within a corridor is important to determine whether a project is feasible or not.

**Safe Routes to School** - A program aimed at making walking and biking to school safer for students, often by improving infrastructure around schools.

**Santa Fe Bicycle Master Plan (BMP)** - A strategic document adopted in 2019 aimed at developing a safer, more interconnected bicycle network in Santa Fe. It sets goals for separated bicycle facilities to encourage cycling as a viable transportation option.

**Stop Bars** - A marked line where vehicles must stop before crossing a bike lane or entering a street, ensuring cyclists' right-of-way is respected.

**Surface Treatment** - Pavement maintenance techniques such as crack sealing and micro-surfacing, applied to bike lanes to ensure smooth surfaces and long-term durability.

**Tight Turning Radius** - A road design feature that forces vehicles to make slower, sharper turns, improving safety for cyclists at intersections and driveways.

**Traffic Calming** - Road design strategies aimed at reducing vehicle speeds, often through physical elements like speed humps or raised crossings, to enhance safety for cyclists and pedestrians

**Visibility and Sightline** - Ensuring unobstructed views for both cyclists and drivers at intersections and driveways, crucial for preventing crashes where bike lanes intersect with vehicle paths.

**Chevron Markings** - Diagonal or arrow-like pavement markings used within bike lanes to indicate conflict zones, such as where vehicles cross over into bike spaces.

**Bike-Friendly Drainage Grates** - Drainage grates designed to prevent cyclists from getting stuck or injured, replacing traditional designs that pose a safety risk to cyclists.

**Average Daily Traffic (ADT)** - ADT represents the average number of vehicles passing a point on a roadway per day, calculated over a longer period, often a week, month, or year. This metric smooths out daily variations (such as weekends or seasonal changes) to provide a more representative daily average. ADT is useful for understanding typical traffic flow patterns and planning infrastructure over time.

# INTRODUCTION

## BACKGROUND

This amendment seeks to build on the 2019 Bicycle Master Plan by evaluating various safer bicycle facilities in the context of Santa Fe's unique conditions, constraints, and opportunities.

The Santa Fe MPO recognizes that **increasing bicycle use as a mode of transportation can significantly contribute to sustainability and quality-of-life goals**. However, safety concerns remain a significant barrier to increased biking. With Santa Fe's diverse street network, which ranges from historical to modern layouts, implementing safer, low-stress bicycle facilities poses unique challenges. **This plan will explore different types of safer bicycle infrastructure**, including protected bike lanes with careful consideration for maintenance, cost, and applicability to local conditions. To conduct this study, the Santa Fe Metropolitan Planning Organization (MPO) has partnered with Pland Collaborative.

## GOAL

This plan will serve as an amendment to the 2019 Bicycle Master Plan, evaluating opportunities and constraints for implementing safer bicycle facilities within the Santa Fe MPO planning area. It will guide discussions on the suitability of different facility types to improve safety, encourage use, and make biking a more viable transportation option in Santa Fe.

## PURPOSE

**Providing multimodal opportunities to the citizens of Santa Fe is essential to achieving the city's equity, climate, and quality of life goals.** However, to achieve successful alternative transportation habits, the **perception and reality of safety in on-road bicycle facilities are significant barriers**. Public interest in safer bicycle facilities, such as protected or separated bike lanes, has been on the

rise nationwide. While there has been a growing push for separated bikeways, their specific applicability to Santa Fe has not been thoroughly explored. **This study evaluates the potential for various safer bicycle facilities within the city and surrounding areas**, considering Santa Fe's unique conditions, constraints, and opportunities.

Moreover, the introduction of new bicycle infrastructure presents potential challenges, including routine street sweeping, snow removal, and the associated costs of equipment and staffing. This plan will consider the benefits of implementing bicycle facilities that are safe, functional, and tailored to Santa Fe's distinct road network.

## EXISTING BIKE PLANNING

The Santa Fe MPO has developed a variety of plans that aim to improve the area's bicycle infrastructure. These plans address a range of issues, from road safety and walkability to integrating bicycle facilities with public transit. By considering different types of infrastructure, such as protected and separated bike lanes, these documents work to make biking a safer and more viable mode of transportation in both urban and rural parts of Santa Fe. The following **summaries highlight the purpose of each plan, its scope of application, and key elements related to safer bicycle facilities**.



### Santa Fe 2020-2045 Metropolitan Transportation Plan

The Santa Fe 2020-2045 Metropolitan Transportation Plan sets the vision for the future of transportation within the metro area, guiding infrastructure investments and policy decisions to develop a connected, multi-modal network.

- Covers all modes of transportation, including roadways, public transit, biking, and walking. One of its key elements is the integration of enhanced bicycle facilities into the overall transportation network.
- Acknowledges the importance of protected and buffered bike lanes as crucial components in creating safer streets for cyclists.
- Advocates for a comprehensive bicycle network tailored to the unique urban context of Santa Fe.

### SANTA FE METROPOLITAN BICYCLE MASTER PLAN 2019

SANTA FE METROPOLITAN PLANNING ORGANIZATION



NEW MEXICO DEPARTMENT OF TRANSPORTATION  
SANTA FE COUNTY  
PUEBLO OF TESUQUE  
CITY OF SANTA FE

### Santa Fe Metropolitan Bicycle Master Plan 2019

The 2019 Santa Fe Metropolitan Bicycle Master Plan provides strategic guidelines for developing bicycle infrastructure in the metropolitan area, aiming to create a safe, accessible, and interconnected bike network that encourages cycling for both transportation and recreation.

- Includes a "Bicycle Design Toolkit" in Appendix A, which contains detailed guidance on various types of bicycle facilities, including separated and buffered bike lanes.
- Outlines specific design standards that prioritize the safety and comfort of cyclists, thereby supporting efforts to make biking a more viable transportation choice.
- Includes a focus on creating an all ages and abilities bicycle network



## Santa Fe Bicycle Design Toolkit

Appendix A of the Santa Fe Bicycle Master Plan serves as a design toolkit, complementing the master plan by offering best practices for planning, designing, and operating various types of bicycle facilities in the Santa Fe area.

- Applies to bicycle infrastructure projects within the city, providing guidelines for consistent, context-sensitive design.
- Places significant emphasis on safer bicycle facilities, including separated and buffered bike lanes, offering detailed standards on dimensions, materials, and intersection treatments.
- Separation from vehicle traffic enhances cyclist safety and makes biking a more attractive transportation option in Santa Fe.



## Multimodal Transition Plan

The Santa Fe Multimodal Transition Plan outlines a roadmap to reduce car dependence, improve public transit, and enhance active transportation infrastructure, supporting a more balanced, sustainable transportation system for the city.

- The plan promotes car-free mobility by enhancing transit, walking, and biking options throughout Santa Fe.
- It supports the city's sustainability goals, aligning closely with Santa Fe's climate and sustainability initiatives.
- Efficient transit and parking are prioritized through expanded transit routes, the addition of new transit hubs, and improved parking management to reduce car dependency.
- Focus area improvements target specific upgrades in Downtown/Railyard, Midtown/Rufina, and Airport Road.
- This plan brings community benefits by offering affordable, low-carbon transit, improving access in underserved areas, and encouraging car-free tourism.

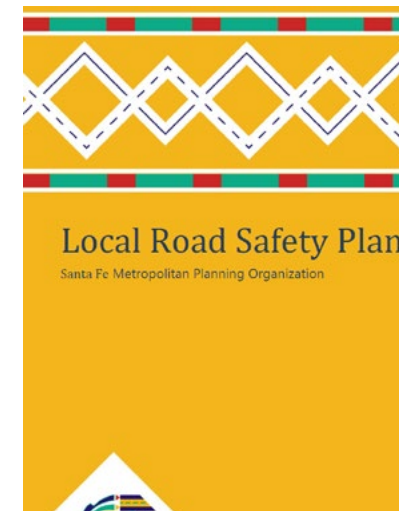

## Local Road Safety Plan 2022

The Local Road Safety Plan 2022 provides a comprehensive framework aimed at reducing fatalities and serious injuries on local roads within the Santa Fe metropolitan region.

- Primary goal is to enhance safety for all road users by identifying and prioritizing targeted improvements.
- Applies to the region's roadways and serves as a guide for implementing various safety measures.
- A key focus of this plan is the integration of separated bike lanes, intersection improvements, and traffic-calming strategies.
- Highlights how separated bike lanes enhance the safety of cyclists and are essential elements of the roadway.

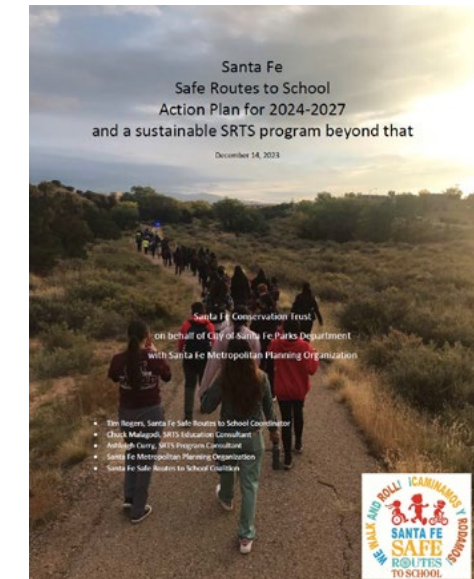

## Safe Routes to School Action Plan 2024-2027

The Safe Routes to School Action Plan plan outlines a comprehensive framework designed to make walking and biking to school safer and more appealing for students and their families.

- Targets school zones across Santa Fe and recommends infrastructure and policy changes to enhance student safety.
- The plan includes improving bicycle facilities near schools, advocating for bike lanes and designated routes to create safe, low-stress environments for young cyclists.
- Recommendations support a network that encourages students to bike more frequently and confidently.



## Pop-Up Protected Bike Lanes Report

The Pop-Up Protected Bike Lanes Report documents the implementation and evaluation of temporary protected bike lanes in Santa Fe, focusing on their impact on cyclist safety, traffic behavior, and public perception.

- ▶ *Case study for future infrastructure planning, providing insights into how protected bike lanes contribute to a safer biking experience.*
- ▶ *Physical barriers help reduce vehicle speeds, enhancing overall road safety for all users.*
- ▶ *Reinforces the importance of protected bike lanes in promoting safer and accessible cycling in urban areas.*



## Pedestrian Master Plan 2015

The Pedestrian Master Plan, adopted in 2015, aims to improve the walkability of Santa Fe by identifying barriers to pedestrian movement and proposing infrastructure enhancements.

- ▶ *Covers the entire city's pedestrian infrastructure, including sidewalks, crossings, and connections to public transit and bike networks.*
- ▶ *Recognizes the importance of integrated transportation systems, including bike lanes.*
- ▶ *Emphasizes the need for a network that accommodates both pedestrians and cyclists safely and effectively, promoting a multi-modal approach to city planning.*

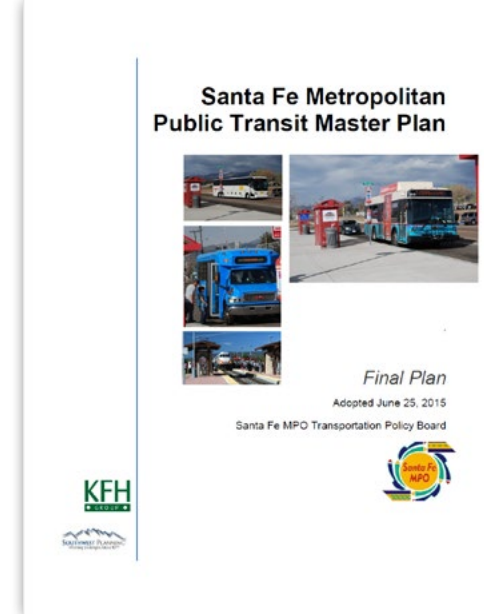

## Santa Fe Metropolitan Public Transit Master Plan 2015

The Public Transit Master Plan of 2015 sets forth strategies to improve the public transit services in Santa Fe, emphasizing increased accessibility, efficiency, and connectivity across different transportation modes.

- ▶ *Covers public transit systems, including bus routes and their integration with pedestrian and bicycle networks.*
- ▶ *Promotes safer bike infrastructure, the plan supports the creation of a multi-modal system that encourages residents to incorporate biking as part of their transit journeys.*



## Santa Fe Midtown Master Plan

The Midtown Master Plan for Santa Fe envisions the redevelopment of the former Santa Fe University of Art and Design site into a vibrant, mixed-use center that prioritizes sustainable urbanism, community engagement, and economic development.

- ▶ *The Midtown Master Plan envisions a vibrant, sustainable mixed-use center on the former university site.*
- ▶ *It creates a walkable community with housing, jobs, and cultural spaces.*
- ▶ *It includes street sections with sidewalk-level bike lanes.*
- ▶ *It includes green infrastructure, affordable housing, and improved connectivity.*
- ▶ *It fosters a cultural and economic hub with arts, education, and community spaces.*
- ▶ *It supports growth, housing diversity, and community identity.*

### KEY TAKEAWAYS

- ✓ **Safety Enhancement:** Protected bike lanes are repeatedly highlighted as a key strategy to enhance cyclist safety, reduce vehicle-cyclist conflicts, and promote low-stress cycling environments, particularly around schools and intersections.
- ✓ **Traffic-Calming and Integration:** Many plans emphasize the role of protected bike lanes in traffic-calming, advocating for their integration into the overall roadway design to benefit all road users.
- ✓ **Infrastructure and Maintenance:** The documents discuss the need for proper maintenance of protected bike lanes, such as regular street sweeping and snow removal, to ensure their effectiveness and long-term usability.

- ✓ **Data-Driven Design:** Several plans recommend using data collection and analysis to inform the placement, design, and evaluation of protected bike lanes, ensuring they meet the community's safety and accessibility needs.
- ✓ **Public Perception and Encouragement:** Protected bike lanes are identified as crucial for encouraging more people to cycle, as public outreach indicates safety concerns are a significant barrier to increased bicycle use. Temporary installations (pop-ups) are noted as valuable for gauging public response and informing future permanent infrastructure.

## OUTREACH OUTCOMES

The **MPO and partners have conducted extensive outreach related to biking facilities in recent years**, gathering valuable insights into the key factors that influence biking behaviors in the community. The results from various surveys and plans, including the 2021 Multimodal Transition Plan, the 2021 Bicycle and Pedestrian Advisory Committee (BPAC) Survey, the 2020-2045 Metropolitan Transportation Plan, and the 2019 Bicycle Master Plan, reveal a common theme: **safety concerns are the primary barriers preventing people from biking more frequently**. The following summarizes some of the key findings and takeaways from this outreach.

### 2021 MULTIMODAL TRANSITION PLAN:

In the 2021 Multimodal Transition Plan, survey participants were asked, “If you would like to bike more (for trips to school, work, errands, or recreation), but don’t, what is the biggest factor or constraint that keeps you from doing so?” From over 2,000 responses, **68% cited Traffic Safety Concerns, 56% noted a Lack of Bike Paths or Bike Lanes, 44% expressed that they Don’t Feel Safe Biking in Bike Lanes, and 36% reported Personal Safety Concerns**.

	# Responses	% Respondents
Traffic safety concerns	483	68%
Lack of bike paths or bike lanes	396	56%
Don't feel safe biking in bike lanes	315	44%
Personal safety concerns	255	36%
Destinations are too far away	163	23%
Things I need to carry are too heavy	155	22%
NA: I am not interested in bicycling more	139	20%
Takes too much time	119	17%
I have a bike I want to use but it needs to be repaired	67	9%
Concerned about bicycle theft/my bike was stolen	12	2%
Disability/Health Issues	8	1%
Weather	6	1%
Other	10	1%
Total Responses	2,128	
Total Individual Respondents	711	100%

### 2021 BPAC SURVEY:

In the 2021 Bicycle and Pedestrian Advisory Committee (BPAC) survey, participants were asked, “If you would like to bike more (for trips to school, work, errands, or recreation), but don’t, what is the biggest factor or constraint that keeps you from doing so?” Among respondents, over **60% cited Traffic Safety Concerns, over 50% pointed to a Lack of Bike Paths or Bike Lanes, and over 35% reported that they Don’t Feel Safe Biking in Existing Bike Lanes**.



Excerpt 2021 BPAC Survey

### 2020-2045 METROPOLITAN TRANSPORTATION PLAN:

In the 2020-2045 MTP survey, participants were asked, “Which of the following barriers influence you the most when considering transportation options?” Among responses, **safety was identified as the second most significant barrier impacting transportation decisions**.

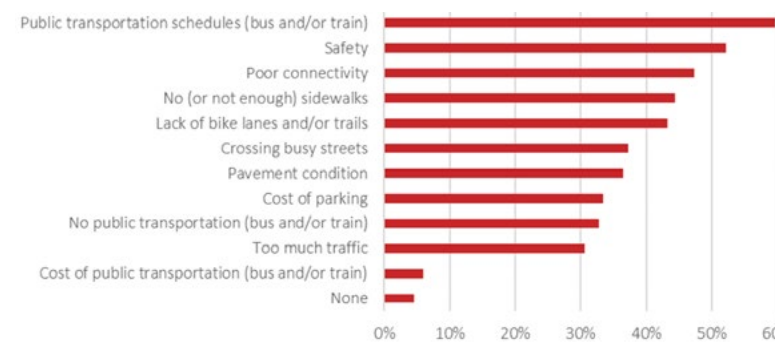

### 2019 BICYCLE MASTER PLAN:

In the 2019 Bicycle Master Plan, participants were asked to select from a list of potential barriers to their ability or willingness to ride a bicycle. **The top six barriers identified were Inattentive Drivers, Difficulty Crossing Major Roads, Speeding Traffic, Riding Close to Moving Cars, Lack of Safe Routes to Destinations, and High Automobile Traffic**—all safety concerns focused on cyclists’ interactions with automobile traffic.

The MPO’s outreach reveals a clear theme: **safety concerns are the main barrier to biking more frequently**. Respondents pointed to traffic safety, lack of bike paths, and discomfort near moving cars, along with issues like inattentive drivers and high traffic volumes. These findings highlight the need for better biking infrastructure and safety improvements.

## SAFETY CONSIDERATIONS

Between **2010 and 2022, 397 people biking were involved in crashes in Santa Fe**. While this number is smaller than pedestrian and vehicle-only incidents, **surveys show that many people feel unsafe biking in the city**, limiting its appeal. Although traditional bike lanes designate space for cyclists, painted lines offer minimal protection against vehicle encroachment. Sideswipe crashes, with 1,612 incidents recorded between 2010 and 2020 in Santa Fe, illustrate how **painted lines and visual cues often fail to prevent collisions**.

**National research indicates that separated bike lanes improve safety**. In a key research article published in 2019, 13 years of data from 12 major U.S. cities were analyzed to determine how several factors, including protected bike lanes, affected road safety.<sup>1</sup> The authors analyzed all traffic fatalities alone and combined them with severe injuries. They looked for significant associations within three variables: travel behavior, such as bike commute mode share, the built environment, and demographics. Their models indicated that **more protected bike lanes and intersection density decreased fatalities and severe injuries**. Their models suggest that increasing the length of protected bike lanes from 25 to 100 feet per square mile led to a 53% reduction in fatal and severe crashes. Other variables significantly associated with traffic fatalities and injuries included:

- ▶ *The percentage of bike commuters (associated with decreased safety).*
- ▶ *The percentage of the population identifying as white (associated with increased safety).*
- ▶ *The percentage of the population aged 15-24 (associated with decreased safety).*
- ▶ *The percentage of the population aged 65 or older (associated with increased safety).*

These results demonstrate that **protected bike lanes are one of the few factors within a city’s control that can reduce traffic fatalities and severe injuries for all road users**.

Protected bike lanes increase safety for all road users through a traffic-calming effect, reducing vehicle speeds. Collisions at slower vehicle speeds are less likely to result in pedestrian and vehicle passenger fatalities.<sup>2</sup>

<sup>1</sup> Marshall, Wesley, Ferenchak, Nicholas. (2019)

<sup>2</sup> Safety as a Speed Problem, Institute of Transportation Engineers

<sup>3</sup> Marshall, Wesley, Ferenchak, Nicholas. (2019)

<sup>4</sup> People for Bikes

<sup>5</sup> The League of American Bicyclists. (2019). Protected Bike Lanes Mean Business.

## GREENHOUSE GAS REDUCTIONS

In cities across the United States and worldwide, **the number of people biking has increased after installing protected bike lanes**. One study, in particular, examined the number of people biking before and after protected bike lanes were installed in five cities in the US. In each of the eight locations, **ridership increased from 21% to 171%**.<sup>3</sup> In follow-up surveys, some riders on each route responded that they would have used a different mode of transportation if the protected bike lane had not been installed.<sup>4</sup> In addition, women reported a greater frequency of biking after the protected bike lanes were installed.

Shifting transportation away from personal vehicles by providing better and safer bicycle routes has several benefits. For individuals, **riding bicycles improves physical and mental well-being**. Regionally, replacing vehicle trips with bicycles **reduces air pollution and greenhouse gas emissions**, thereby improving residents’ air quality and reducing climate change contributions.

Transportation in Santa Fe and nationwide is the most significant contributor to greenhouse gas emissions. **The Sustainable Santa Fe Plan outlines a goal of carbon neutrality by 2040**, and transportation mode shift away from personal vehicles is a key strategy to achieve this.

**Reducing reliance on personal vehicles minimizes the need for parking**, which can free up valuable land for other uses such as housing and businesses, which will, in turn, create more density and walkable, bike-able neighborhoods.

## ECONOMIC GROWTH POTENTIAL

Studies have linked protected bike lanes with economic growth, the most comprehensive review is a 2013 report by People for Bikes and Alliance for Biking & Walking: “Protected Bike Lanes Mean Business”<sup>5</sup>. The report outlines four major ways that protected bike lanes boost economic growth:

- ▶ **Boosting land value** through accessibility. As redevelopment creates density, protected bike lanes allow more people to access the new assets without increasing congestion.
- ▶ Helping companies **recruit talented workers**. Being able to skip traffic congestion and use safer bicycle facilities to get to work is a perk that attracts young talent to good jobs and allows employers to save money on parking expenses.
- ▶ Making **healthier, more productive employees**. Protected bike lanes allow more people to bike, which means more physical activity and lower health care costs for employers. Physical activity can also increase employee productivity.
- ▶ **Increasing sales**. Retailers can serve more people with less parking if people bike there, and people biking are easy to attract and more likely to return again and again.

## EQUITY CONSIDERATIONS

Transportation and housing together account for an average of 49% of household income, with the **cost of vehicle ownership adding financial strain** across income levels. In Santa Fe, 33% of the population earns 200% or less of the federal poverty level, and 14% fall below the poverty line. Black, American Indian, Native Hawaiian, Pacific Islander, and Hispanic communities are disproportionately impacted by these financial burdens, facing both the high costs of car ownership in a car-dependent environment and the transportation challenges that arise when lacking a vehicle. According to an MPO analysis of police officer reported race and ethnicity on crash reports from 2010-2022:

- ▶ *Hispanic residents are 1.5 times more likely than non-Hispanic whites to be involved in a fatal pedestrian or bicycle crash.*
- ▶ *American Indian residents face an 11.3 times higher risk of fatal bicycle or pedestrian crashes than whites.*
- ▶ *Risk of bicycle or pedestrian injury is 1.9 times higher for American Indians and 2.8 times higher for Black individuals than for white residents.*

### National data confirms that Black and American Indian

### populations experience higher traffic fatality rates.<sup>6</sup>

While police-reported race and ethnicity data may have limitations, national statistics consistently show disproportionate risks for these communities. Safer bicycle infrastructure would provide a disproportionately positive benefit for these vulnerable populations, enhancing safety and accessibility.

#### KEY TAKEAWAYS

- ✔ **Protected bike lanes significantly reduce traffic fatalities and injuries**, decreasing crashes by up to 53% when their density increases fourfold. They create a traffic-calming effect, slowing vehicle speeds and enhancing overall road safety.
- ✔ **Increased Ridership and Reduced Emissions:** Cities with protected bike lanes see ridership increases of 21% to 171%, encouraging a shift from car use to biking.
- ✔ **Enhanced bike infrastructure reduces air pollution** and supports Santa Fe's carbon neutrality goal for 2040.
- ✔ **Protected bike lanes boost land values** and attract urban redevelopment.
- ✔ **Protected bike lanes help companies by offering congestion-free commuting** and promoting healthier, more productive employees.
- ✔ **Retailers benefit from increased sales** as biking becomes a more accessible transportation option.
- ✔ **Protected bike lanes improve access to essential services**, particularly for the 20%-25% of Santa Fe residents who cannot drive.
- ✔ **They offer a positive impact on vulnerable groups**, providing safer and more accessible biking options.

<sup>6</sup> USDOT (2022) *Evaluating Disparities in Traffic Fatalities by Race, Ethnicity, and Income*

# MAINTENANCE

Maintenance of bike facilities is important for smooth, safe, and comfortable travel, as bicycles are far more sensitive to surface irregularities and debris than cars. Proper maintenance **enhances the user experience and encourages more people to use these facilities**, ultimately promoting a healthier and more sustainable transportation system.

The goal of bike facility maintenance should be to ensure smooth surfaces, prevent cracks, eliminate ridges between pavement sections or along gutter edges, and keep bike lanes free of blockages and debris. By prioritizing regular maintenance and addressing issues as they arise, the Santa Fe metro area can ensure bicycle facilities remain safe, accessible, and enjoyable for cyclists of all skill levels.

## BEST PRACTICES FOR MAINTENANCE

It is recommended to maintain infrastructure in good condition by paying attention to both the riding surface and protective barriers, along with regularly sweeping bike lanes

to remove debris that could pose a risk to cyclists.

NACTO advises **applying finer seal coat rock in bike lanes for smoother, safer surfaces** and ensuring utility cuts are backfilled to the original pavement smoothness. The FHWA recommends consistent bike lane maintenance through its Bicycle and Pedestrian Program, suggesting that **maintenance needs be factored into the overall life cycle costs of bicycle facilities**. Planning for long-term upkeep during the design phase can help reduce future repair expenses. Additionally, **routine inspections**, especially after severe weather events, can help keep bike lanes free of hazards such as debris, potholes, and overgrown vegetation. The agency also underscores the importance of high-visibility markings and clear signage, in alignment with NACTO's guidance on ensuring lane lines and pavement markings are legible for all users, which is vital for user safety and comfort.

**NMDOT acknowledges the importance of clear standards** for pavement quality, vegetation management, and snow removal specific to bike lanes. They emphasize that snow removal for bike lanes should receive the same priority as



An example of bicycle facilities on Chestnut Street in Philadelphia, PA, before and after improvements.

motor vehicle lanes, ensuring safer, passable conditions during winter months. **NMDOT also recommends regular vegetation trimming to maintain sightlines** and clearance for cyclists, reinforcing the importance of consistent maintenance.

## Design & Longevity

The long-term upkeep of a bike facility starts with its design. **Building high-quality, durable infrastructure is critical to reducing ongoing maintenance needs.** Permanent features, such as continuous curbs or raised facilities, may come with higher upfront costs but result in lower long-term maintenance expenses than temporary elements like bollards or planters, which are prone to vehicle damage and require frequent replacement.

## Vegetation

Vegetation management is crucial for ensuring full clearance and maintaining proper sightlines for cyclists. **Mowing and landscaping should occur before vegetation encroaches into the bike facility.** If overhanging vegetation affects the street, a vertical clearance of at least eight feet should be maintained above the bike lane. Any debris resulting from vegetation maintenance should be promptly swept out of the bike lane to keep it clear for riders.

## Snow

The City of Santa Fe has a **priority-based system for snow and ice removal**, focusing first on main arterials (Priority 1 streets) to ensure access for emergency services and critical transportation routes, followed by commercial routes (Priority 2) and then certain residential streets (Priority 3). Snow removal crews use a mixture of salt and cinders in a four-to-one ratio to melt snow and ice while minimizing corrosion to infrastructure.

No specific requirements exist for snow removal on bike infrastructure in Santa Fe. However, the New Mexico Department of Transportation's (NMDOT) New Mexico Prioritized Statewide Bicycle Network Plan recommends that **bike lanes in urban areas and shoulders in rural areas along popular bicycling routes should be plowed, with snow storage on shoulders avoided unless absolutely necessary.**

For the Santa Fe metro area, strategies for addressing snow removal on bike infrastructure should be developed.

## Surface Treatment

Standard pavement preservation methods should be applied to bike lanes, taking into account the unique needs of cyclists. Crack sealing is a common preventative measure that helps protect the surrounding pavement and slows the growth of cracks. However, rubberized crack seals can create a slippery surface for cyclists, so they should be applied with minimal ridges and only as a temporary solution.

When conducting overlays, such as slurry seals or micro-surfacing, it is important to avoid creating ridges at the gutter or any abrupt grade changes, as these can create safety issues for cyclists. Similarly, treatments like heater scarification, revamping, and milling should ensure smooth transitions between treated and untreated pavement to provide a comfortable riding experience.



*Appropriately plowed bike lane. - Cambridge MA*

## Drainage Grates

Traditional drainage grates with longitudinal slots pose safety risks for cyclists. When installing bicycle facilities on existing roads, it is essential to inventory and replace such grates with bike-friendly designs. New bicycle facilities should always include drainage grates designed with cyclists' safety in mind.



*Unsafe Grate for Bicycles - Bike PGH*

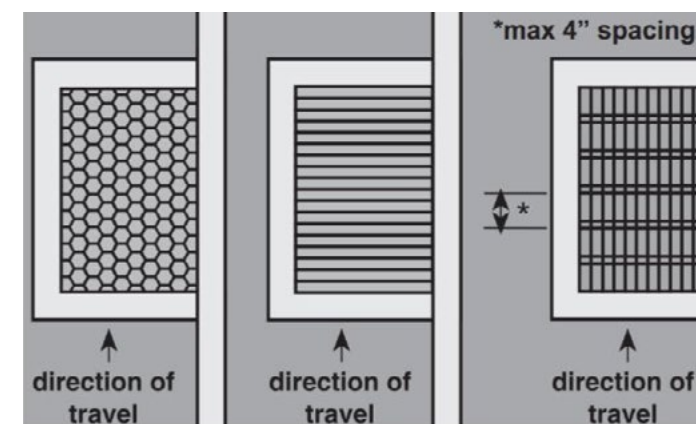

*Bicycle Safer Grates - Oregon Bicycle & Pedestrian Guide*

## Monitoring

Agencies should aim to achieve and maintain bike facilities that are in acceptable condition. However, maintenance should not hinder the installation of safer bike facilities. After installing new infrastructure, the agency should actively monitor its condition to determine the optimal frequency for maintenance activities. There may be a tolerance level regarding infrastructure conditions, such as debris or snowfall before ridership begins to decrease.

## KEY TAKEAWAYS

- ✓ **Proper maintenance improves the cyclist experience**, encourages more usage, and supports a healthier, more sustainable transportation system.
- ✓ **Maintenance should be factored into the overall project budget**, including regular upkeep and ensuring equipment availability.
- ✓ **Durable, high-quality infrastructure minimizes long-term maintenance** needs and reduces future repair costs.
- ✓ **Routine maintenance**, such as sweeping debris, filling cracks, and inspecting conditions after severe weather, **ensures safety, accessibility, and comfort for all users.**
- ✓ **Replace traditional grates with bike-friendly designs** to minimize risks and enhance safety.
- ✓ **Establish a system to monitor infrastructure conditions**, determine optimal maintenance schedules, and identify thresholds where debris or other factors begin to reduce ridership.

## PEER CITY MAINTENANCE EXAMPLES

### Proactive Maintenance Planning

A successful maintenance strategy for bike lanes should **focus on building internal maintenance capacity, implementing data tracking systems, and providing targeted training.** This training can be for internal teams or through partnerships with external organizations, depending on the city's resources and needs. **Many cities proactively invest in bike-specific maintenance equipment,** such as narrow sweepers designed for bike lanes, as they recognize that maintaining a high standard from the start is crucial to the long-term success of an effective bike network. Cities that take a proactive approach to maintenance and community involvement find that they can manage costs and enhance bike lane quality over time. Examples of such practices include:

- ▶ **San Luis Obispo:** Contractors are hired to manually sweep bike lanes using leaf blowers, though the city plans to bring this task in-house to reduce costs.
- ▶ **Austin:** The 311 system is trained to accept bike maintenance requests from residents, which are then forwarded to the appropriate department for quick response.
- ▶ **Community Partnerships:** In some cities, community groups help maintain standalone planters or vegetation within bike lanes that have continuous curbs, adding aesthetic value while reducing the city's maintenance burden.

### Specialized Equipment

Traditional street sweepers often require at least 8.5 feet of clearance, which exceeds the typical width of bike lanes. To address this, cities will have more success if they prioritize acquiring and using narrower, bike-specific maintenance equipment. By investing in these tools and training staff on their use, cities can maintain a high standard of bike lane cleanliness and safety rather than delaying maintenance quality until appropriate tools are obtained. **Many cities, including Austin, Flagstaff, and Boulder, have invested significantly in specialized in-house equipment and staff dedicated to bike lane upkeep.** Examples of these efforts

include:

- ▶ **San Luis Obispo:** Currently contracts out maintenance services but plans to purchase a narrow sweeper and shift operations in-house as their bike network grows. They are also considering pedal-powered bike sweepers, which could be operated by city staff or local community groups, fostering a sense of community involvement in the city's maintenance efforts.
- ▶ **Flagstaff:** Uses a Bobcat with various attachments, including a street sweeper and snowplow, showing the versatility of multi-purpose equipment for year-round bike lane maintenance.



San Luis Obispo uses hand held commercial leaf blowers to clear their bicycle facilities.



Less specialized vehicles, like Boulder's Intimidator or Flagstaff's Bobcat, can be used for multiple purposes by using attachments.



The Deluvo 6000 sweeper used in Boulder.



Pedal powered sweepers are a cheaper alternative, fulfill maintenance needs in cities with lower miles of bicycle facilities, and are a good opportunity to contract out with a community bike group.



### Public Reporting Systems

Daily users of bicycle facilities are often the best source of information regarding the condition of these routes, making it essential to develop accessible and varied methods for cyclists to report maintenance issues. Cities with well-established reporting systems offer multiple options for cyclists to submit feedback, ensuring quick attention to maintenance needs and improving overall safety.

- ▶ **Tucson:** Cyclists can report issues through several channels, including contacting the Bicycle and Pedestrian Program Manager at the Pima County Department of Transportation directly, submitting an online form, or using physical postcards available at local bike shops and government buildings.
- ▶ **Austin:** The 3-1-1 system handles bike lane maintenance requests, allowing cyclists to report issues by phone, online, or through a mobile app. Each method ensures that maintenance requests are routed to the appropriate departments for timely resolution.

These comprehensive reporting options in both cities help to ensure that bicycle facilities are well-maintained and responsive to the needs of daily users.

## Dedicated Funding

Securing dedicated local funding for the maintenance of bicycle facilities is a priority in many cities. Maintenance should be integrated into the overall project budget and included within the agency's operating budget to ensure consistent and reliable upkeep. By proactively budgeting for maintenance during the facility's development, agencies can avoid the need to chase external funding or partnerships later, ensuring that high-quality standards are met from the outset.

FIGURE 2. PEER CITIES ROUTINES SNAPSHOT

City	Action	Frequency
Boulder	Sweeping	Monthly, or within 4 days of snow storm to clear up de-icer.
	Snow Plowing	Snow removal 24 hours during active storms and until conditions are returned to normal
Flagstaff	Re-stripping	Annually
	Sweeping	2 - 4 times a year.
San Luis Obispo	Blowing	Monthly
Tuscon	Sweeping	Seasonally

FIGURE 3. PEER CITIES EQUIPMENT SNAPSHOT

City	Equipment	Comments
Boulder	Deluvo 6000 Sweeper	For monthly sweeping.
	Intimidator UTV	For plowing snow.
Flagstaff	Bobcat with plow	For plowing snow.
San Luis Obispo	Leaf blower	For monthly clearing.
	Pedal Powered Sweeper	Exploring procurement.
Tuscon	Mathieu Azura Flex Mc210	Narrow sweeper

### KEY TAKEAWAYS

- ✓ **Proactive Maintenance Planning:** Establishing cross-departmental strategies early, including communication, budgeting, and training, is essential to ensure long-term maintenance success.
- ✓ **Interim Maintenance Solutions:** Cities like San Luis Obispo use contractors for tasks such as manually sweeping bike lanes with leaf blowers to address immediate needs. Over time, they transition to in-house maintenance to reduce costs.
- ✓ **Community Partnerships:** Maintenance of standalone planters and vegetation can be handled by organized community groups, providing a low-cost solution.
- ✓ **Dedicated Maintenance Routines:** Bike lanes require more frequent sweeping schedules to address debris buildup, which poses hazards to cyclists, particularly along curbs.
- ✓ **Multipurpose Equipment:** Flagstaff's use of a Bobcat with interchangeable attachments (e.g., for snowplowing and sweeping) offers a cost-effective, multi-functional maintenance approach.
- ✓ **Public Reporting Systems:** Tucson employs a comprehensive and low-cost maintenance reporting system using phone hotlines, online forms, and physical postcards available at bike shops.

# INTERSECTION CONFLICTS

Santa Fe has a rich history and unique development patterns, presenting significant challenges in incorporating modern bike infrastructure. The city's historic layout, with its narrow streets and limited right-of-ways, was designed long before cars were common, let alone the need for dedicated bike lanes. Conversely, as Santa Fe expanded in the 20th century, streets were primarily built for vehicles and not people walking and biking. As a result, **frequent curb cuts, constrained urban spaces, and narrow roadways make it difficult to implement safer bike infrastructure** without encountering conflicts between cyclists and vehicles.

The city's built environment, including numerous driveways and curb cuts, street design, and frequent vehicle access points requires thoughtful planning to minimize conflicts between cars and cyclists. **To address these challenges, bike lane designs must focus on improving visibility, clarifying right-of-way precedence, and reducing vehicle speeds** to better protect cyclists.

Managing intersections, curb cuts, and driveways is a critical element of ensuring cyclist safety and reducing conflicts with vehicles. When vehicles exit driveways or turn at an intersection, they often cross bike lanes, creating potential hazards. Best practices emphasize design strategies that enhance visibility, establish clear travel precedence, and slow vehicle movements to keep cyclists safe. These strategies, outlined below, should be tailored to each specific location, taking into account the available right-of-way and unique challenges.

## BEST PRACTICES

### Pavement Markings

[\[NACTO Urban Bikeway Design Guide\]](#)  
[\[FHWA Separated Bike Lane Planning and Design Guide\]](#)

- ▶ **High-Visibility Bike Lane Markings:** Ensure the bike lane

*remains clearly marked across all driveways using bike lane symbols and colored pavement (often green) to signal to drivers that they are crossing a dedicated cycling space.*

- ▶ **Bold Markings Across Driveways:** Ensuring bike lane markings span the width of driveway exits provides a visual cue to drivers that they are crossing a bike lane, increasing the likelihood they will yield to cyclists.
- ▶ **Colored Pavement:** Use colored pavement (green or red) at high-conflict areas like driveway crossings to increase driver awareness and reduce conflicts by clearly marking the bike lane's presence.
- ▶ **Chevron or Diagonal Markings:** These markings within the bike lane further reinforce that drivers are entering a conflict zone, alerting them to proceed with caution.



An example of green pavement used to highlight a bicycle facility at a driveway.

### Raised Crossings

[\[NACTO Urban Street Design Guide\]](#)

- ▶ **Raised Bike Lanes at Driveways:** Elevating the bike lane at driveways creates a raised crossing, slowing down vehicles and improving the visibility of cyclists. This is especially effective in reducing conflicts in high-traffic areas with frequent curb cuts.
- ▶ **Speed Control:** Raised crossings encourage slower vehicle speeds, providing safer crossings for cyclists and reinforcing cyclist right-of-way.

## Narrow or Eliminate Driveways

*[NACTO Urban Bikeway Guide, AASHTO Guide for the Development of Bicycle Facilities 7.9.11]*

- ▶ **Minimize Driveway Widths:** Narrowing driveways reduces the time bicycles spend crossing driveways, slows down motor vehicles exiting driveways, and making cyclists more visible. This practice is especially beneficial for reducing conflict in high-traffic environments.
- ▶ **Eliminate Driveways and Access Management:** Driveways, mid-block left turns, and intersection turn movements can be controlled or eliminated to reduce conflicts.

## Visibility and Sightlines

*[NACTO Urban Bikeway Design Guide, AASHTO Guide for the Development of Bicycle Facilities 5.5]*

- ▶ **Clear Sightlines:** Ensure that both drivers and cyclists have unobstructed views by removing obstructions like parked cars or vegetation near driveways, commonly referred to as "daylighting". This improves visibility and helps drivers see cyclists before crossing the bike lane.
- ▶ **Warning Signage:** Installing signs such as "Yield to Cyclists" near driveways reminds drivers to check for cyclists before crossing the bike lane, reducing the likelihood of conflicts.

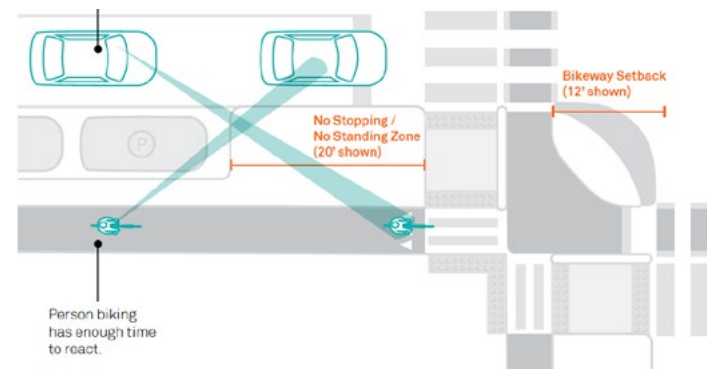

NACTO Clear Sight Distance.

## Tight Turning Radii

*[FHWA Small Town and Rural Multimodal Networks]*

- ▶ **Design with Tight Radii:** Creating driveway exits with tight turning radii forces vehicles to exit more slowly, reducing the likelihood of rapid, unsafe exits that could pose a danger to cyclists.
- ▶ **Slower Vehicle Speeds:** Tighter radii naturally reduce vehicle speeds, improving the likelihood that drivers will see and have time to yield to cyclists.

## Designated Stop Zones for Vehicles

*[NACTO Urban Bikeway Design Guide]*

- ▶ **Stop Lines Before the Bike Lane:** Implementing clear stop lines before bike lanes at driveways ensures drivers pause and yield to cyclists before crossing the bike lane.
- ▶ **Staggered Stop Lines:** Staggering stop lines separates vehicle wait zones from the bike lane, making it easier for drivers to identify where to stop and look for cyclists.

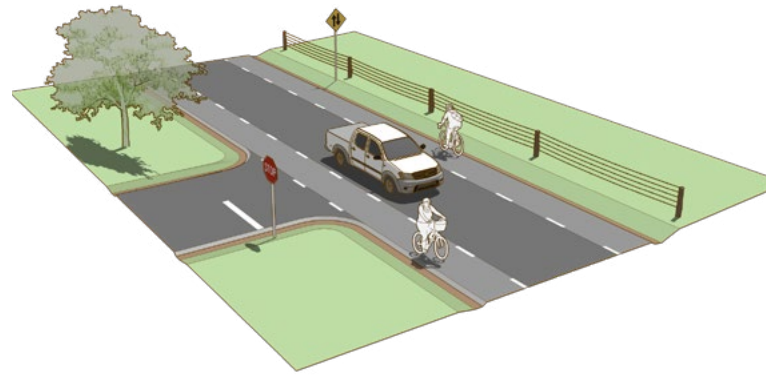

Example of a designated stop zones for vehicles from the FHWA Small Town and Rural Multimodal Networks

## Protected Intersections

*[AASHTO Guide for the Development of Bicycle Facilities 7.9.7]*

- ▶ **Minimize Bicycle and Vehicle Conflicts:** Protected intersections include physical barriers such as corner islands to provide protection and visibility from turning vehicles.
- ▶ **Clarify Right-of-Way Assignment:** Protected intersections can include bicycle signalization and travel through intersection delineation that clarifies where bicycles are expected and how turning movements should be made.

## Right-of-Way Enforcement and Education

*[NACTO Urban Street Design Guide]*

- ▶ **Enforce Right-of-Way Laws:** Ensure local traffic laws clearly define cyclists' right to proceed and enforce compliance at driveway exits. Public campaigns can also educate drivers on the importance of yielding to cyclists in bike lanes.
- ▶ **Driver Education Campaigns:** Informing drivers about how to safely navigate bike lanes at driveways can improve compliance and reduce conflict.

## PEER CITY EXAMPLES

Addressing conflicts between bicycle facilities and frequent curb cuts is essential for cyclist safety. Several cities have implemented effective engineering strategies to mitigate these conflicts:

### Albuquerque, New Mexico

**Location:** Martin Luther King Jr. Avenue.

**Strategies:** Albuquerque upgraded bike lanes along Martin Luther King Jr. Avenue by implementing green-painted lanes and flexible bollards to create a physical barrier between cyclists and vehicles. The green paint improves visibility at intersections and driveways, alerting both drivers and cyclists to potential conflict points, while the bollards reinforce separation and safety.



Protected bike facility in Albuquerque utilizing green paint and flexible bollards

### Tucson, Arizona

**Location:** 3rd Street and Treat Avenue Bicycle Boulevard.

**Strategies:** Tucson developed bicycle boulevards utilizing neighborhood streets to expand the low-stress biking network. These projects include traffic calming measures and enhanced crossings to improve safety for cyclists and pedestrians. By prioritizing bicycle traffic on certain streets and implementing features like curb extensions and traffic circles, Tucson effectively reduces conflicts at driveways and intersections. At driveways and other conflict areas, Tucson utilized clear markings to alert drivers and cyclists of conflict areas.



Bike facility improvements in Tucson utilizing raised medians and other measures to reduce conflicts at driveways and intersections.

### Raton, New Mexico

**Location:** Sugarite Avenue.

**Strategies:** Raton's protected two-way bike facility on Sugarite Avenue includes a raised median with green paint at intersections. The project includes cutouts for driveway access, ensuring that the bike path remains continuous while accommodating curb cuts. Clear pavement markings signal to cyclists and drivers that they should look for potential conflicts.



Protected bike facility in Raton utilizing green paint and raised medians.

### Portland, Oregon

**Location:** SE Division Street Corridor.

**Strategies:** Portland employs high-visibility green paint across bike lanes at intersections and curb cuts to alert both drivers and cyclists. Setback bike lanes with landscaped buffers create physical separation, providing space for vehicles to yield before crossing the bike lane. Clear signage reminds drivers to yield at curb cuts, reducing conflicts at driveway entrances.



Protected bike facility in Portland utilizing green pain and curb stops.

## Cambridge, Massachusetts

**Location:** Vassar Street, near the MIT campus.

**Strategies:** Cambridge utilizes raised bike lanes along Vassar Street, elevating the facility to sidewalk level across driveways. This design encourages drivers to slow down as they cross, similar to a speed table effect. High-contrast pavement markings and textured surfaces at each driveway crossing improve visibility and emphasize the priority of the bike lane.



Protected bike facility in Cambridge utilizing high-contrast pain and a raised bike lane.

## Boulder, Colorado

**Location:** Folsom Street, Baseline Road, and 28th Street, Boulder, CO.

**Strategies:** Boulder implemented protected bike lanes on Folsom Street, Baseline Road, and portions of 28th Street to enhance cyclist safety and comfort. The design incorporates physical barriers, including concrete curbs, flexible delineators, and raised medians, to create a clear separation between cyclists and vehicle traffic. Landscaped buffers and painted zones are used to improve visibility and add aesthetic value to the lanes.

To address driveways and intersections, the bike lanes feature clear pavement markings and signage to alert drivers and cyclists of potential conflict points. These measures, aligned with NACTO and FHWA standards, demonstrate Boulder's commitment to creating safer, more functional, and visually appealing bike infrastructure.



Curb-stop barriers on Baseline Road in Boulder, CO.



Curb separators on Folsom Street Boulder, CO.

## Flagstaff, Arizona

**Location:** Beaver Street and Butler Avenue.

**Strategies:** Flagstaff implemented a pilot project installing separated bike lanes on Beaver Street and Butler Avenue. The design includes the installation of a concrete curb to physically separate bicyclists from vehicles, providing a more comfortable cycling experience. To address curb cuts and driveways, the project incorporates clear pavement markings and signage to alert both drivers and cyclists of potential conflict points. Additionally, the city is working to modify and re-install delineator posts that have been hit or damaged by vehicles, ensuring the integrity of the separation.

These examples demonstrate that through thoughtful design—such as clear markings, physical separations like bollards and medians, and strategic accommodations at curb cuts—cities can effectively mitigate conflicts between bicycle facilities and driveways, enhancing safety and comfort for all road users.



Concrete curb barriers in Flagstaff, AZ.

### KEY TAKEAWAYS

- ✓ Improve visibility, clarify right-of-way, and slow vehicles to protect cyclists.
- ✓ Use high-visibility and colored pavement to mark bike lanes at driveways.
- ✓ Elevate bike lanes at driveways to slow vehicles and enhance visibility.
- ✓ Reduce driveway widths to limit crossing time and improve cyclist visibility.
- ✓ Ensure clear sightlines and use "Yield to Cyclists" signage near driveways.
- ✓ Tight Radii: Design driveways with tight turning radii to slow vehicle exits.
- ✓ Add stop lines before bike lanes to encourage drivers to yield to cyclists.
- ✓ Enforce cyclist right-of-way laws and educate drivers on compliance.

# FACILITY DESIGN

Facility design choices play a crucial role in creating safer bike infrastructure. National engineering guides, such as the new AASHTO Guide for the Development of Bicycle Facilities, 5th Edition (2024), introduce updated strategies to enhance safety and improve separation from fast-moving vehicle traffic. Different types of facilities—such as protected bike lanes, protected intersections, and off-street infrastructure—help reduce direct interaction between cyclists and motor vehicles, creating a safer environment for all road users. AASHTO defines the two fundamental elements of a separated bicycle lane:

- › Separation from motor vehicles with vertical elements
- › Separation from pedestrians with a vertical element, a change in elevation, or a detectable change of surface materials.

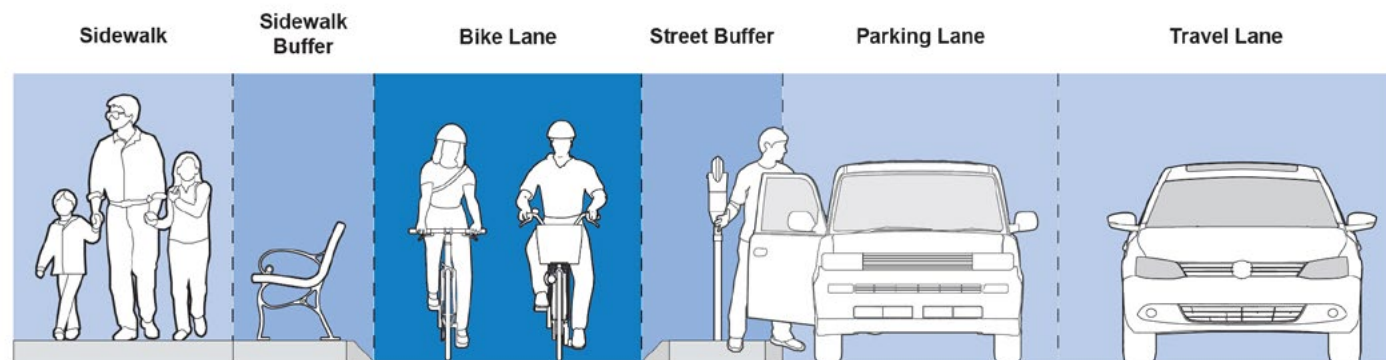

Zones of a Separated Bicycle Facility - AASHTO Guide for the Development of Bicycle Facilities, 5th Edition.

## BASIC CONSIDERATIONS

Designing safer bike facilities requires careful attention to key factors that enhance rider comfort, safety, and efficiency. Ensuring smooth elevation, adequate lane width, and proper separation from vehicles and pedestrians helps create a more accessible and predictable cycling environment. The following are basic considerations for achieving safer bike infrastructure:

- › **Smooth Elevation:** Minimize changes in bike lane elevation for a consistent riding surface.
- › **Bicycle Volume:** Consider current and future bicycle traffic; safer designs can boost ridership.
- › **Lane Width:** Provide sufficient width for cyclists to pass or ride side by side.
- › **Bike Lane Edges:** Ensure space accommodates pedals and handlebars without hazards.
- › **Street Buffer:** Maintain adequate horizontal and vertical separation from vehicles.
- › **Sidewalk Buffer:** Design clear separation between cyclists and pedestrians.

## BIKE LANE SURFACE

Asphalt and concrete are the preferred surfaces for bike lanes. This is because of their smooth and stable surface with few joints in the riding surface, as compared to permeable pavers. In the case of a concrete bike lane, joints should use a square edge to maintain a smooth riding surface, and longitudinal joints should be avoided.



Facility in Salt Lake City, Utah.

## TYPE OF BICYCLE FACILITIES

**Protected/Separated Bike Lanes:** These lanes physically separate cyclists and motor vehicle traffic, using barriers such as bollards, curbs, planters, or parked cars. This separation enhances safety by reducing the risk of collisions, especially with fast-moving vehicles. Protected bike lanes can be at street level with added buffers or slightly elevated. Side paths are similar in design to two-way separated bike lanes, except pedestrian and bicycle traffic are mixed. Studies have shown that separated bike lanes decrease crash rates and increase the likelihood of people choosing to bike, thereby promoting a safer and more accessible biking environment.



PROTECTED / SEPARATE BIKE LANES

**Protected Intersections:** These are specifically designed to reduce the chances of collisions at crossings. They use corner islands, bike-specific traffic signals, and designated crossings to clearly separate bicycle and motor vehicle paths. This design slows vehicle turns and improves visibility for drivers and cyclists. By guiding all users to predictable paths, protected intersections significantly reduce the chances of collisions and improve the overall flow of traffic.

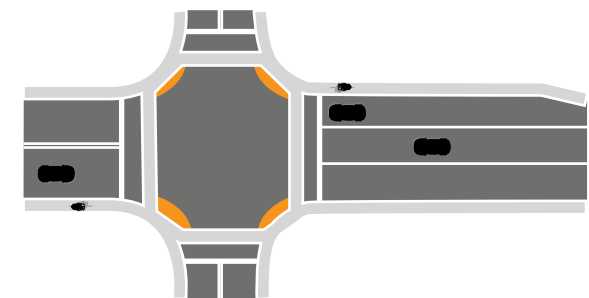

PROTECTED INTERSECTION

**Off-Street Infrastructure:** This includes multi-use paths, greenways, and dedicated bike trails that are entirely separate from the roadway network. Off-street infrastructure provides a safer and more relaxed environment for cyclists by eliminating direct interactions with motorized traffic. These paths often run through parks, along rivers, or other scenic areas, making biking not just a mode of transportation but also a recreational activity, allowing cyclists to feel more relaxed and at peace.

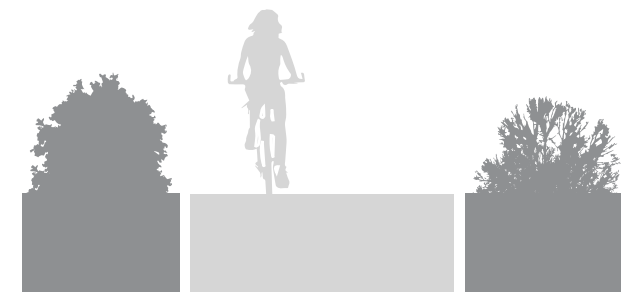

MULTI-USE TRAILS

## FACILITY ORIENTATION

Different facility configurations offer distinct benefits and challenges. Each design must consider factors like roadway space, traffic flow, and potential conflicts between cyclists, vehicles, and pedestrians. Research indicates that specific configurations may be more accessible depending on the street's design and existing infrastructure. For example, one-way bike lanes are familiar to most users but require more space due to the need for dual buffer zones, while two-way lanes may conserve space by requiring only one separate facility, but drivers may not expect contraflow bicycle traffic. Additionally, center or median bike lanes can reduce curbside conflicts, especially in areas with frequent turning vehicles, driveways, or transit stops, making them a viable option where space is limited or curbside interactions are a concern. By carefully considering these options, planners and engineers can create bicycle facilities that balance safety, space efficiency, and ease of implementation.

### One-way

One-way bike lanes on both sides of the street is a typical design that most users expect. However, this requires two buffer zones which consumes more roadway space.

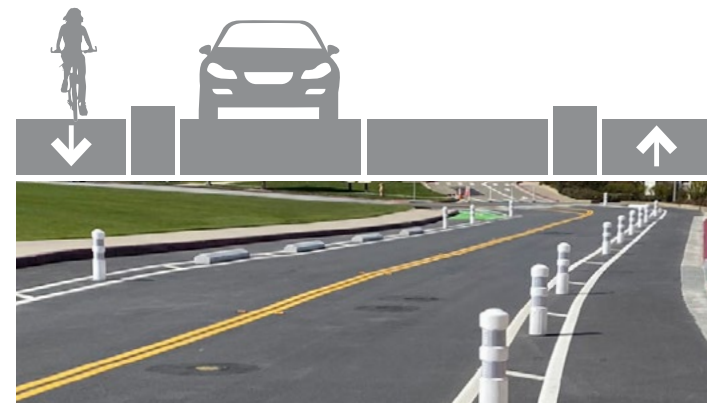

One-way bike lanes in San Francisco, CA. Kittelson & Associates, Inc.

### Two-way

Two-way bike lanes on one side of the street minimize conflicts on the opposite side, while saving space as only one separated facility is needed. Appropriate countermeasures are needed to alert drivers to look for contraflow bicycle traffic.

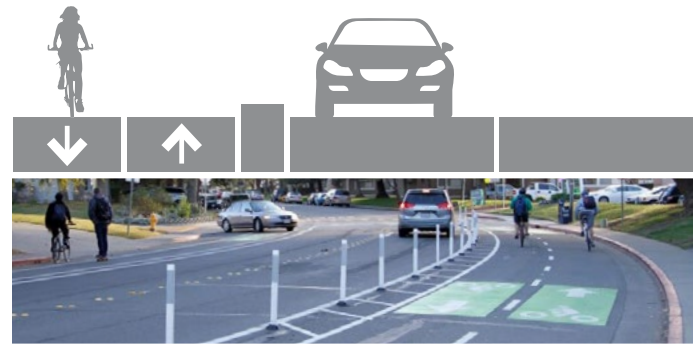

Two-way bike lanes in Davis, CA. City of Davis

### Median

Median bike lanes take up the same amount of space as curb side two-way lanes, while avoiding curbside conflicts.

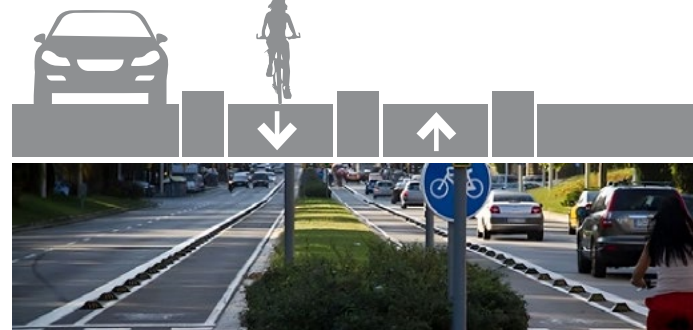

Median bike lanes in Barcelona, Spain.

### Center

Center bike lanes may be considered where there are frequent curb-side conflicts with the bike lane, like turning cars, many driveways, or a frequent transit line.



Center bike lanes. Bike Athens

## CURBS ADJACENT TO BIKE LANES

Curb design plays a critical role in the safety and functionality of bike facilities, influencing accessibility, separation, and overall rider experience. The type of curb used can impact a cyclist's ability to navigate the space, avoid hazards, and interact with adjacent sidewalks or roadways. Different curb designs offer varying benefits, from reducing pedal strike risks to enhancing separation from vehicles and pedestrians. The following curb types each serve distinct purposes in creating safer and more effective bike infrastructure:

### Sloping Curbs

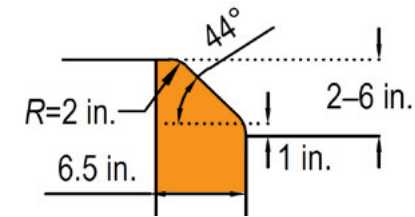

Sloping curb, AASHTO Bicycle Facilities, 5th Edition

Benefits:

- ▶ Reduces pedal strike hazards.
- ▶ Eases access to the sidewalk.



Austin, Texas

### Mountable Curbs

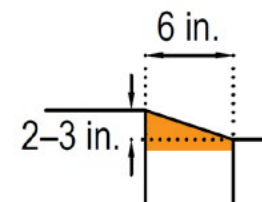

Mountable curb, AASHTO Bicycle Facilities, 5th Edition

Benefits:

- ▶ Most easily traversed by cyclists.
- ▶ Most forgiving angle to reduce pedal strikes.



### Vertical Curbs

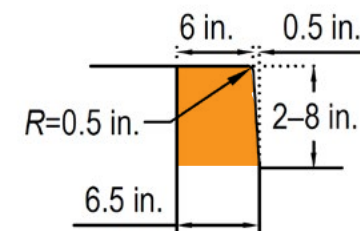

Vertical curb, AASHTO Bicycle Facilities, 5th Edition

Benefits:

- ▶ Most clear delineation and separation.



Ada County, Idaho

## FACILITY OPTIONS

A variety of buffer options can be employed to separate cyclists from vehicular traffic. Each type of buffer comes with its own dimensional standards, strengths, and weaknesses, allowing municipalities to select the option that **best suits their road conditions, budget, and design goals**. From simple painted buffers to more substantial raised medians and bike lanes, these facilities can enhance both cyclist safety and the overall streetscape.

Options such as painted buffers and flexible delineators (also known as flex posts or tubular markers) offer cost-effective and easy-to-install solutions, though they provide limited physical protection and require regular maintenance. Curb stops and on-street parking buffers provide heavier, more durable barriers, with curb stops being a long-standing,

budget-friendly solution. Planters and raised medians offer the dual benefit of physical separation and aesthetic enhancement, while raised bike lanes or cycle tracks fully segregate cyclists from vehicles by elevating the bike lane to a different grade. Each buffer type can be mixed with other buffer types on a street to meet design and budget requirements.

Each of these solutions serves a unique purpose and **meets different needs, ranging from quick, low-cost implementation to long-term, durable infrastructure** with greater protection. The following sections detail the specifics of each option, including their dimensional standards, advantages, and limitations.

### PAINTED BUFFER

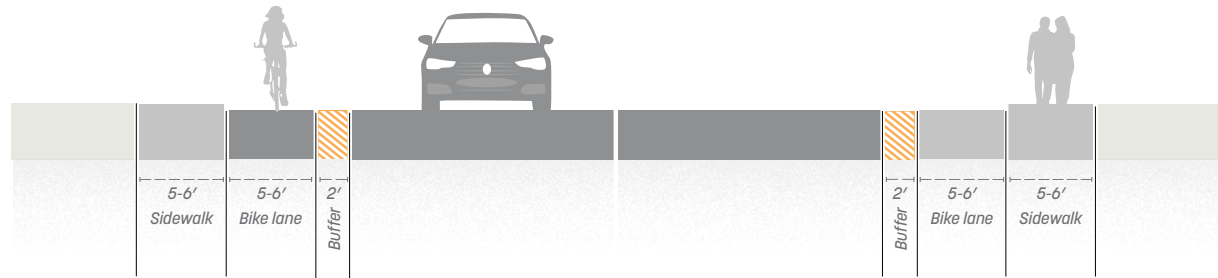

### FLEXIBLE DELINEATORS OR BOLLARDS

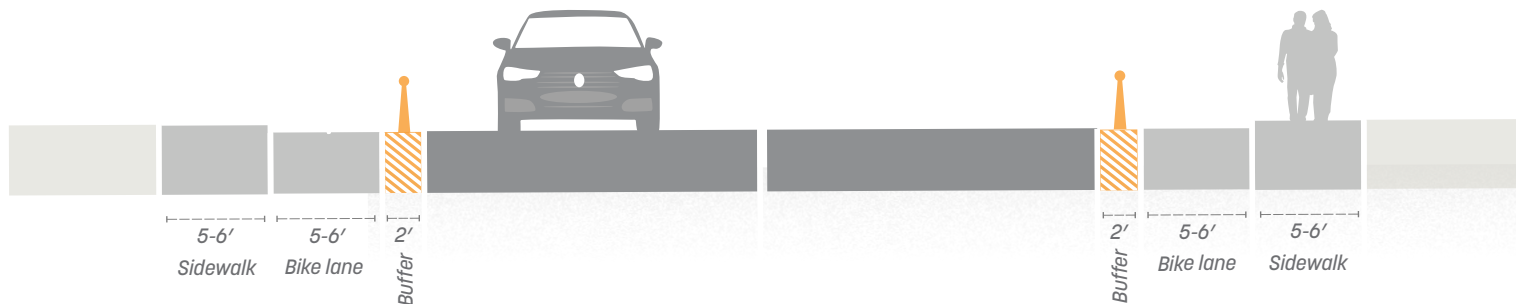

### CURB STOPS

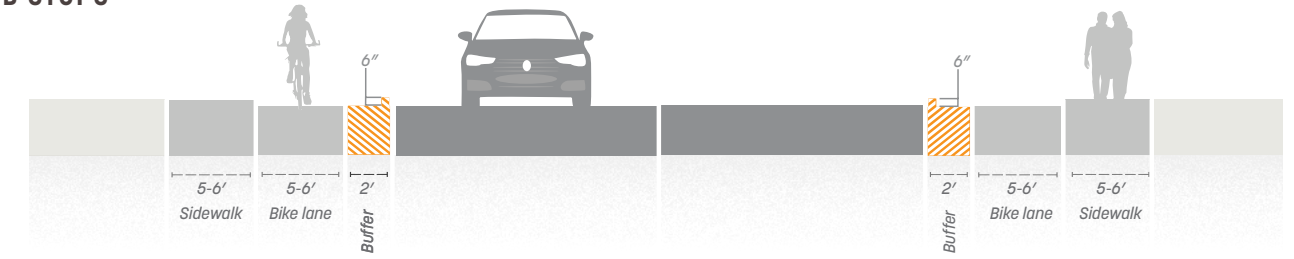

### ON-STREET PARKING



### PLANTERS

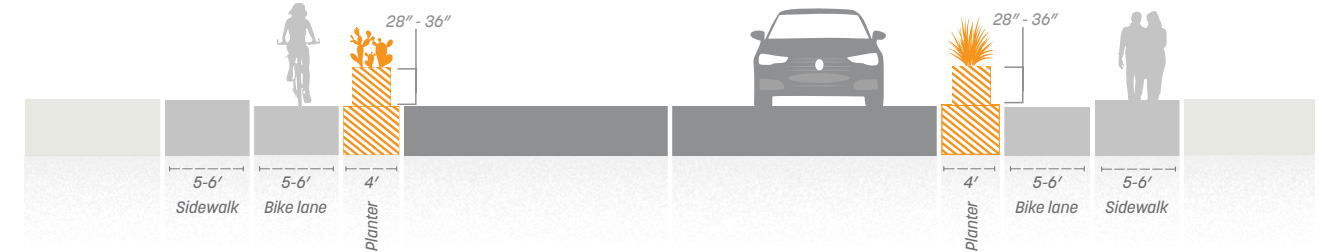

### RAISED MEDIAN

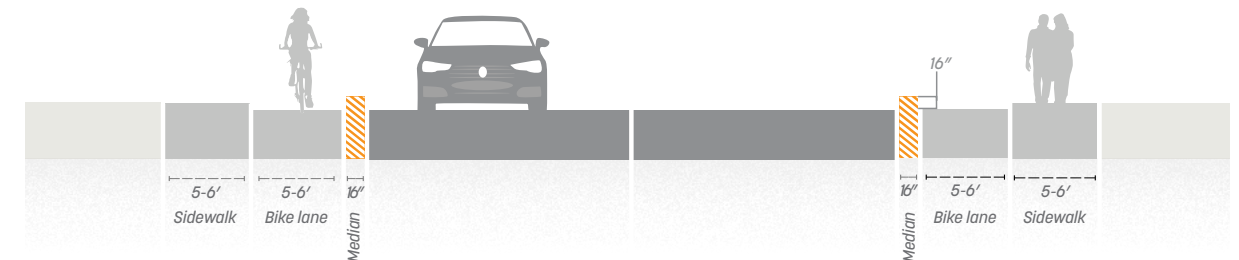

### RAISED BIKE LANE

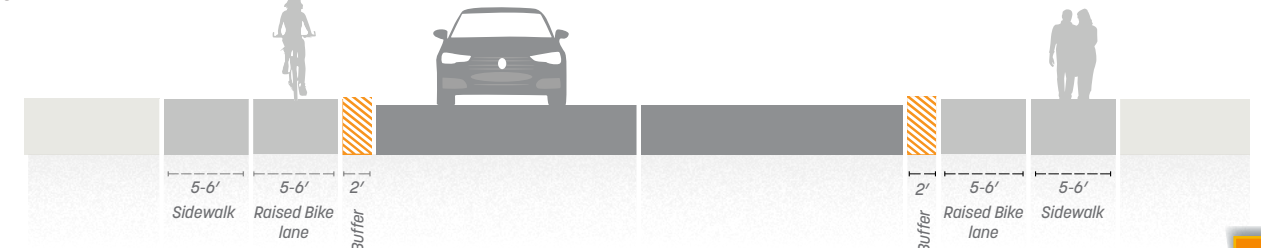

## PAINTED BUFFER

**ALSO KNOWN AS: STRIPED BUFFERS, MARKED BUFFERS, PAINTED SEPARATION ZONES**

A painted buffer in a bike lane is a designated space, typically marked with striped lines, that separates cyclists from vehicle traffic or parked cars. It provides an added layer of safety by **creating extra space between cyclists and vehicles**, reducing the risk of collisions, particularly from “dooring” incidents or vehicles encroaching into the bike lane.

While painted buffers enhance cyclist safety and comfort, they also have limitations. Since they do not offer a physical barrier, **their effectiveness relies on driver visibility and compliance**. In high-traffic or high-speed areas, painted buffers may not provide adequate protection. Additionally, debris can accumulate within the buffer, and without regular maintenance, worn or faded markings can reduce visibility and safety. Despite these drawbacks, painted buffers remain a cost-effective solution that can significantly improve the safety and functionality of bike lanes, particularly in urban environments.

**FIGURE 4. PAINTED BUFFER DIMENSIONAL STANDARDS**

<b>Bike Lane Width</b>	5' - 6' typically, or more.
<b>Buffer Width</b>	18" - 3'
<b>Striping Type</b>	Often marked with diagonal stripes, chevrons, or cross-hatching
<b>Other Considerations</b>	On roads with higher speeds or heavy traffic volumes, use wider buffers.

**FIGURE 5. PAINTED BUFFER STRENGTH + WEAKNESSES**

<b>Strengths</b>	<ul style="list-style-type: none"> <li>Provides visual separation from traffic and reduces dooring risk.</li> <li>Inexpensive and easy to implement.</li> <li>Serves as a visual cue to keep drivers out of bike lanes.</li> <li>Narrows perceived lane width, helping to slow traffic.</li> </ul>
<b>Weaknesses</b>	<ul style="list-style-type: none"> <li>Relying on visual separation rather than physical doesn't feel as protected to cyclists.</li> <li>Requires frequent repainting as markings wear out.</li> <li>Less effective on high-speed or high-traffic roads where more separation is needed.</li> <li>Relies on drivers compliance, which may not always happen.</li> </ul>

**FIGURE 6. PAINTED BUFFER SECTION**

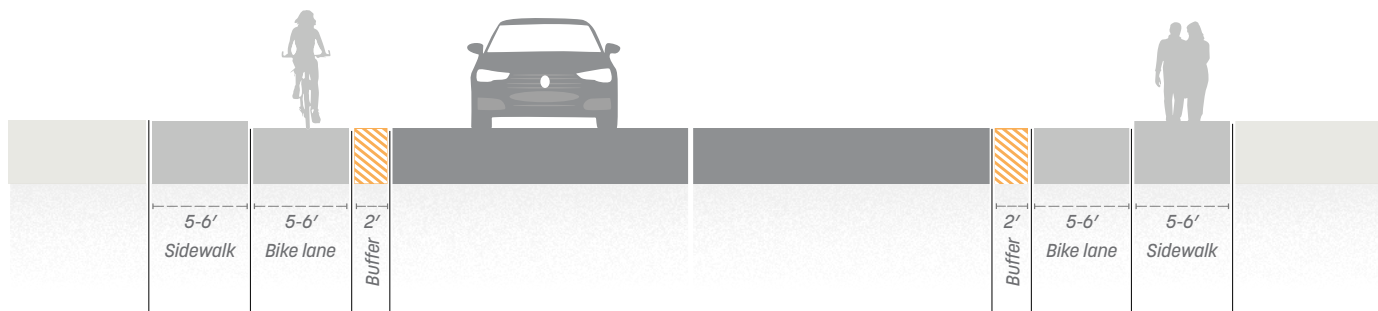

### PAINTED BIKE LANE PRECEDENT IMAGERY



*A buffered bike lane on Taylor Ranch Rd on the Westside of Albuquerque.*



*Painted bike lane in Detroit combined with green bike boxes.*



*A buffered bike lane Austin, Texas*



*A buffered bike lane Seattle, Washington*



*Painted bike lane in Portland*

## CONCLUSION

When designing safer and effective bicycle facilities, a range of buffer options is available, each offering unique benefits and drawbacks. The choice of buffer depends on the municipality's goals, budget, and road conditions. Options such as painted buffers and flexible delineators are cost-effective and easy to install but provide limited physical protection and require regular maintenance. Heavier options like curb stops and on-street parking buffers provide more durable separation but come with their own challenges, such as cost and maintenance.

Planters and raised medians not only offer strong physical separation but also enhance the streetscape's aesthetic value. However, they require more space, and their higher installation costs must be factored in. Raised bike lanes, or cycle tracks, provide complete physical separation by elevating the lane, offering the highest level of cyclist safety at a higher cost.

Each solution meets different needs, from quick and low-cost implementations to long-term infrastructure projects, allowing for flexibility in addressing both safety and urban design considerations.

## KEY TAKEAWAYS

- ✓ **Painted Buffer:** Provides a low-cost, easy-to-implement visual separation but offers no physical protection, requires frequent maintenance, and is less effective on high-speed roads.
- ✓ **Flexible Delineators / Bollards (Flex Posts):** Offers physical separation and visibility, slows traffic, and is less expensive than permanent barriers, but requires frequent replacement, provides limited protection, and can be damaged during snow removal.
- ✓ **Curb Stops (Parking Stops):** Durable, long-lasting protection with minimal maintenance needs and good performance in all weather conditions, but higher installation costs, potential drainage issues, and limited access for emergency vehicles.
- ✓ **On-Street Parking as Buffer:** Provides strong protection using existing infrastructure, offering high perceived safety for cyclists and traffic calming, but exposes cyclists to dooring risks and depends on the presence of parked cars.
- ✓ **Planters:** Combines solid protection with aesthetic and environmental benefits, supporting stormwater management, but requires regular upkeep, occupies more space, and has higher installation and maintenance costs.
- ✓ **Raised Median (Concrete Curbs):** Offers strong, continuous separation and contributes to traffic calming, with minimal maintenance required, but is costly to install, requires significant space, and is difficult to modify.
- ✓ **Raised Bike Lane (Cycle Track):** Provides full physical separation from traffic, maximizing cyclist safety and visibility while enhancing streetscape aesthetics. It offers a smooth, low-maintenance riding surface but requires significant construction investment, more road space, and is difficult to retrofit on existing roadways.

# RECOMMENDATIONS

Based on the findings from national best practices and the specific challenges unique to Santa Fe's road network, several key strategies are recommended to enhance bicycle safety and infrastructure.

Santa Fe's growing interest in sustainability and quality of life aligns with national trends, where cities have successfully reduced traffic fatalities and increased ridership through the installation of safer bicycle facilities. Evidence shows that these facilities create a traffic-calming effect, reduce vehicle speeds, and result in fewer crashes involving both cyclists and pedestrians.

**This section provides specific recommendations for implementing safer bicycle facilities in Santa Fe, balancing the city's unique constraints with proven design strategies.** These recommendations focus on the types of bike lanes, buffer designs, and maintenance strategies that will best

support the city's goals of enhancing safety, encouraging ridership, and contributing to broader environmental and economic objectives. By considering both short-term, low-cost solutions and long-term infrastructure investments, Santa Fe can make meaningful progress in building a bike-friendly city.

In the following section we discuss the recommended bike facility improvements, how they relate to the local context, what their maintenance needs are, and how much they might cost.

Throughout this section, **Yucca Street is used to illustrate how each type of bike infrastructure could be implemented** on a typical Santa Fe street. Many different roads in Santa Fe could also fit the types of bike infrastructure described in this section.



## VERTICAL POSTS

ALSO KNOWN AS: FLEX POSTS, TUBULAR MARKERS.

Flexible delineators, also referred to as “plastic posts,” “flex posts,” or “tubular markers,” are plastic poles placed continuously within the buffer zone adjacent to bike lanes. One of the key advantages of these posts is their low upfront cost. However, they often require frequent replacement due to being easily damaged. While some are made of hard plastic, many are constructed from polyurethane, providing greater flexibility and durability.

FIGURE 7. FLEXIBLE DELINEATORS / BOLLARDS

<b>Bike Lane Width</b>	5' - 6' typically, or more.
<b>Buffer Width</b>	2' mid-block 6' - 20' at intersections
<b>Post Spacing</b>	Typically 10' - 40' between posts. (FHWA)
<b>Post Dimensions</b>	Typically 28" - 36" tall (Seattle DOT)

FIGURE 8. FLEXIBLE DELINEATORS / BOLLARDS STRENGTH + WEAKNESSES

- |                   |  |
|-------------------|--|
| <b>Strengths</b>  | <ul style="list-style-type: none"> <li>Provides a physical barrier between cyclists and vehicles, enhancing safety.</li> <li>Makes bike lanes more visible to drivers, especially at night or in poor weather.</li> <li>Encourages slower vehicle speeds by narrowing the perceived lane width.</li> <li>Prevents vehicles from entering the bike lane or parking in it.</li> <li>Can withstand minor impacts from vehicles without significant damage.</li> <li>Less expensive than permanent barriers but still offers strong protection.</li> </ul> |
| <b>Weaknesses</b> | <ul style="list-style-type: none"> <li>Offers minimal protection against larger or higher-speed vehicles.</li> <li>Can become damaged or knocked over and need frequent replacement.</li> <li>May trap debris in the bike lane, requiring regular cleaning.</li> <li>Can be less effective or damaged during snow removal operations.</li> </ul>   |

FIGURE 9. FLEXIBLE DELINEATES OR BOLLARDS

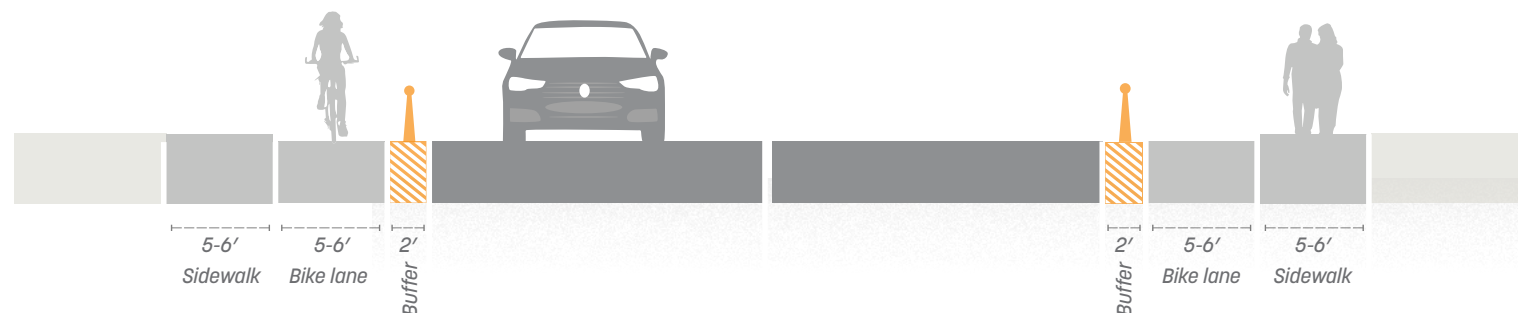

### FLEXIBLE DELINEATORS PRECEDENT IMAGERY



## Vertical Posts Design Strategies

Selecting vertical posts, such as flexible delineators or bollards, to buffer a bike lane offers various options in terms of durability and aesthetics. A painted buffer is essential for delineation regardless of the post type, with commonly used materials like thermoplastics, acrylics, and epoxies selected for their durability and visibility.

**Flexible delineators** are the most widely used type of bicycle lane delineator in the United States. Despite their popularity, they are the least durable and offer minimal aesthetic enhancement, making them **more suitable as an interim solution** with limited long-term value.

In contrast, **concrete or metal bollards**, positioned at the higher end of the spectrum, **provide greater durability and aesthetic flexibility**. Larger bollards can be customized in color, material, and shape, allowing them to complement the unique design and character of streets in Santa Fe.

**FIGURE: 10. DIMENSIONAL STANDARDS**

<b>Bike Lane Width</b>	5' - 6' typically, or more. (FHWA)
<b>Street Buffer</b>	2' mid-block Widths varies at intersections
<b>Post Spacing</b>	Typically 10' - 40' between posts. (FHWA)
<b>Post Dimensions</b>	Typically 28" - 36" tall (Seattle DOT)

The example of Yucca Street illustrates the minimal impact that installing a protected bike lane can have on existing road conditions. Yucca Street already has 6-foot-wide bike lanes, exceeding the minimum required width for collector streets. Adding a 2-foot buffer to both directions of the bike lanes is feasible by reducing the 16-foot-center turning lane to 12 feet, which still exceeds the 11-foot minimum for vehicle travel lanes. Within this buffer, various options for vertical posts can enhance the safety of the bike facility by improving visibility and providing physical protection for cyclists.

**FIGURE: 11. HIGH-LEVEL COST ESTIMATE + MAINTENANCE NEEDS**

<b>Retrofit Cost Estimate</b>	\$20 - \$40 per linear foot (Installing posts on existing roads with minimal roadwork)
<b>New Construction Cost Estimate:</b>	\$50 - \$70 per linear foot (Includes installation of posts during road construction with prepared buffer space)
<b>Maintenance Requirements:</b>	Frequent replacement due to vehicle damage, regular sweeping.
<b>Annual Maintenance Cost:</b>	\$5 - \$10 per linear foot (for post replacement and cleaning)

*\*This high-level cost estimate provides a general guide based on typical industry standards but may vary significantly due to factors like local costs, site conditions, design preferences, and regulatory requirements, and should not be considered a definitive projection without detailed assessment.*

### A WORD FROM AASHTO:

AASHTO recommends bike lane widths based on bicycle traffic volume and the presence of curbs. For bike lanes with vertical posts at street level, the lane is adjacent to only one vertical curb—next to the sidewalk. **The recommended widths for a one-way separated bike lane at street level are:**

Peak Hour Directional Bicyclist Volume	One-Way Separated Bike Lane Width (Adjacent to One Vertical Curb) (ft.)	Street Buffer Zone
Minimum	4'	-
< 150	6' - 8'	6'*
150 - 750	8' - 9.5'	
> 750	≥ 9.5'	

*\*Wider buffers are recommended for multi-lane roads with speed limits over 35 mph*

- ✔ Vertical elements should be visible to approaching bicyclists and motorists.
- ✔ In constrained conditions where the 6' buffer is not feasible factors should be assessed to identify a practical minimum.
- ✔ Along roadways with posted speed limits of 30 mph or less the buffer can be eliminated. Vertical posts can be placed on the white line between the bike lane and roadway.
- ✔ Clear zone and buffer width may be different in lower-speed urban areas and suburban communities.

## YUCCA STREET



### EXISTING

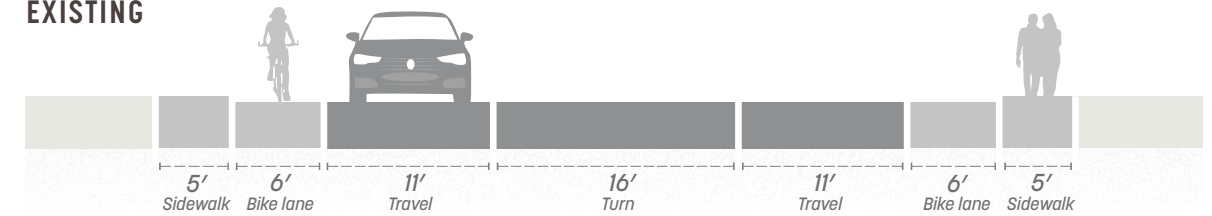

### EXAMPLE

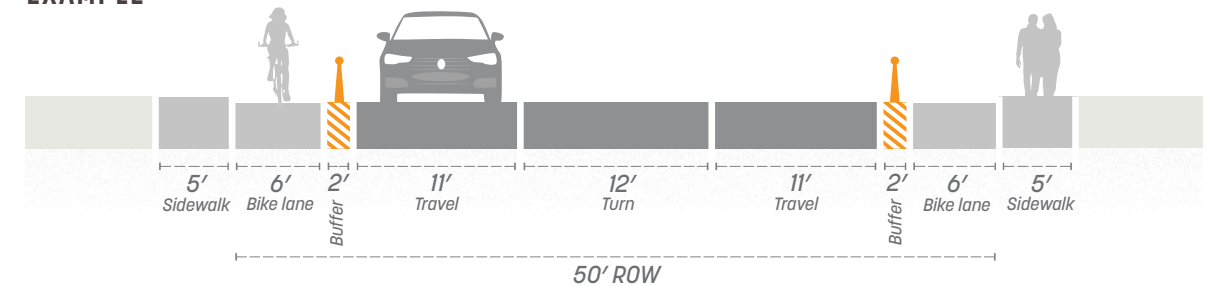

## Vertical Posts Design Elements

### VERTICAL POST

Flexible delineators are a popular choice for buffering bike lanes because they are cost-effective, widely used, and easy to install, making them ideal for interim solutions that quickly improve safety.



Painted bike lanes are a popular feature of many safer bicycle facilities to ensure clear lane delineation, even with vertical posts.



### PAINTED BIKE LANE

### THERMOPLASTIC PAINT

A painted buffer is typically present to delineate separation between the bicycle and car travel lanes. In some cities, like Atlanta, GA, there are examples of bollards protecting bike lanes without a painted buffer.



## ON-STREET PARKING

ALSO KNOWN AS: PARKING LANE, FLEX ZONE.

Cyclists can be separated from moving traffic by placing a parking lane between the curbside bike lane and the travel lane. Parked cars then act as a heavy and highly visible barrier that protects cyclists from moving vehicles. The buffer between the bike lane and the parked cars is ideally three feet, to make room for peoples' interactions with their cars, like opening doors. Using parked cars to create a safer biking facility is a **great option if retaining street parking is a high priority** for that given street, while still offering a high degree of separation from moving traffic.

FIGURE: 12. ON-STREET PARKINGS DIMENSIONAL STANDARDS

Bike Lane Width	5' - 6' typically, or more.
Buffer Width	Ideally 3'
Parking Lane	7' - 8' (FHWA)

FIGURE: 14. ON-STREET PARKINGS STRENGTH + WEAKNESSES

Strengths	<ul style="list-style-type: none"> <li>Provides a strong, consistent separation between cyclists and moving traffic.</li> <li>Utilizes existing infrastructure, avoiding the need for new construction.</li> <li>Offers a high level of perceived safety, which can attract more cyclists.</li> <li>The presence of parked cars can help slow down traffic by visually narrowing the roadway.</li> <li>Efficiently uses available road space by combining parking and bike lane protection.</li> <li>Cyclists are only exposed to passengers exiting vehicles.</li> </ul>
Weaknesses	<ul style="list-style-type: none"> <li>Parked cars can obstruct drivers' view of cyclists, especially at intersections or driveways.</li> <li>Debris can build up in the bike lane without regular sweeping.</li> <li>Can complicate access for emergency vehicles or loading zones adjacent to the bike lane.</li> </ul>

FIGURE: 13. ON-STREET PARKING SECTION

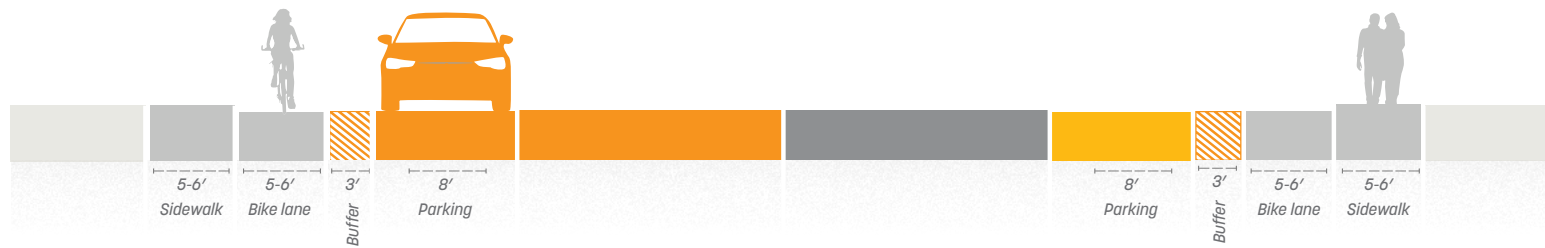

### PARKED CARS PRECEDENT IMAGERY



## On-street Parking Design Strategies

Using on-street parking as a buffer for bike lanes is a **cost-effective solution that typically requires only lane restriping**, especially if the street already accommodates parking. The standard buffer between the bike lane and parked cars is three feet, allowing for vehicle interactions, such as door opening, while providing a significant level of separation from moving traffic. This approach is ideal for streets where retaining parking is a priority, however, the parking should end with enough distance before intersections and conflict points so that cyclists are visible to turning motorists.

At its simplest, a parking-protected bike lane can be implemented by reconfiguring the existing lane layout, relocating the parking lane between the travel lane and the bike lane during routine street repaving or restriping. For a more robust design, additional elements like flexible delineators can be installed in the buffer to prevent vehicles from encroaching into the bike lane. Signage may also be placed at the beginning and end of blocks to clearly demarcate the bike lane and designate parking areas, further enhancing the facility's effectiveness.

FIGURE: 15. DIMENSIONAL STANDARDS

Bike Lane Width	5' - 6' typically, or more.
Buffer Width	3'
Parking Lane	7' - 8' (FHWA)

### A WORD FROM AASHTO:

AASHTO recommends bike lane widths based on bicycle traffic volume and the presence of curbs. For bike lanes with vertical posts at street level, the lane is adjacent to only one vertical curb—next to the sidewalk. **The recommended widths for a one-way separated bike lane at street level are:**

Peak Hour Directional Bicyclist Volume	One-Way Separated Bike Lane Width (Adjacent to One Vertical Curb) (ft.)	Street Buffer Zone
Minimum	4'	2'*
< 150	6' - 8'	2-4'*
150 - 750	8' - 9.5'	
> 750	≥ 9.5'	

\*A 4' buffer prevents door zone conflicts. A 2' buffer is possible but may overlap with the pedestrian step-out zone.

- ✓ A minimum 4' buffer should be provided along on-street parking.
- ✓ The buffer may be reduced to 2', but this could encroach on the pedestrian step-out zone and create conflicts.
- ✓ Vertical elements are recommended in low-occupancy parking areas.
- ✓ Vertical elements should be placed with consideration for parked vehicles and door clearance.
- ✓ Pavement markings should delineate the buffer.
- ✓ Vertical elements should be added at intersections and where parking is prohibited.

FIGURE: 16. HIGH-LEVEL COST ESTIMATE + MAINTENANCE NEEDS

Retrofit Cost Estimate	\$1 - \$5 per linear foot (Utilizing existing parking spaces, only restriping needed)
New Construction Cost Estimate:	\$20 - \$50 per linear foot (May involve constructing new parking spaces alongside new road)
Maintenance Requirements:	Regular sweeping of bike lanes, refreshing paint every 3 years.
Annual Maintenance Cost:	\$0.50 - \$1 per linear foot (for post replacement and cleaning)

*\*This high-level cost estimate provides a general guide based on typical industry standards but may vary significantly due to factors like local costs, site conditions, design preferences, and regulatory requirements, and should not be considered a definitive projection without detailed assessment.*

## YUCCA STREET



### EXISTING

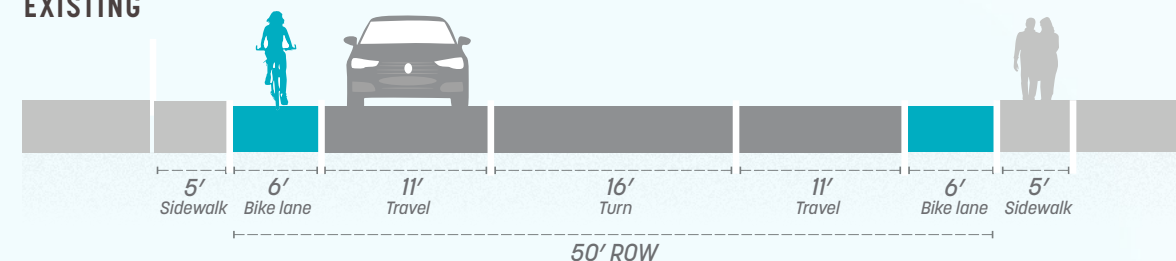

### EXAMPLE

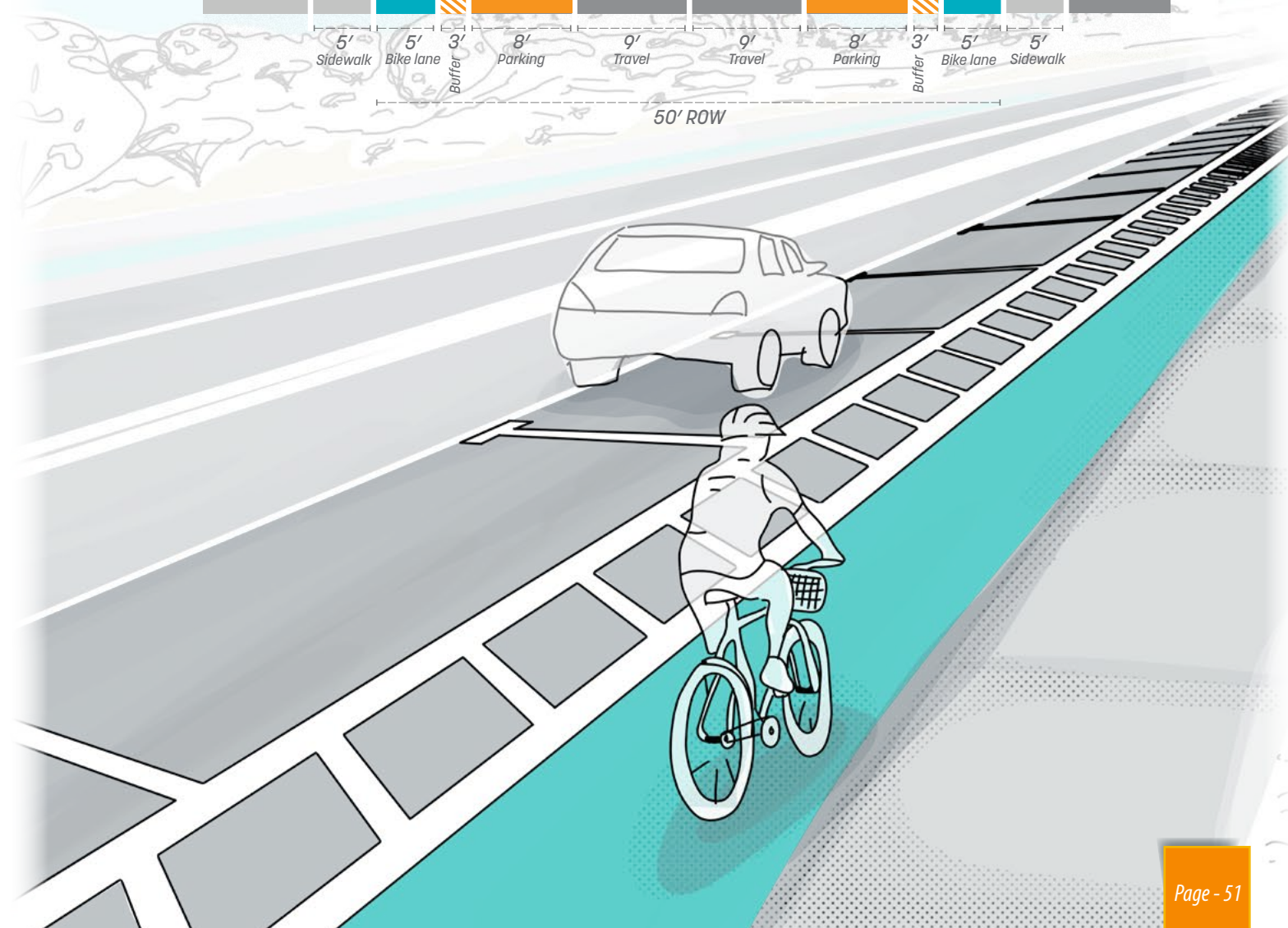
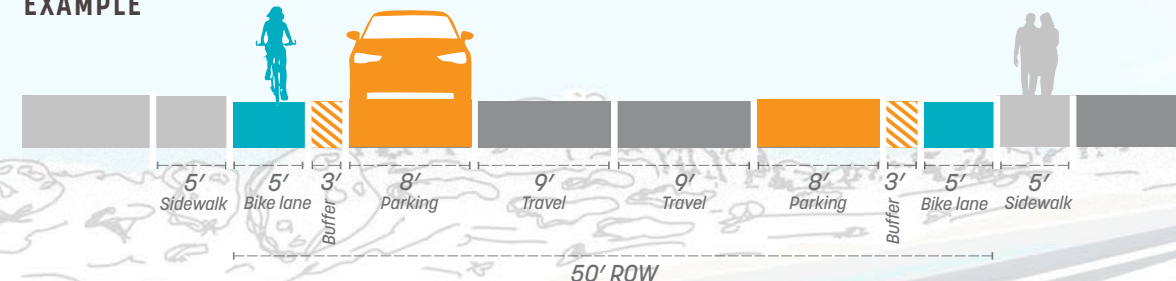

**ON-STREET PARKING DESIGN ELEMENT**

**PARKING LANE**

A lane of parked cars provides a high level of separation between cyclists and vehicle traffic. This can be achieved simply by restriping a road with existing street parking.



**PAINTED BIKE LANE**

Painted bike lanes are a popular feature of many safer bicycle facilities nationwide, even with adjacent parking, for clear delineation.



**THERMOPLASTIC PAINT BUFFER**

A buffer between the parking and bike lanes is typical to provide room for swinging car doors. Sometimes, vertical elements are placed in the buffer for a more comfortable rider experience and to ensure that cars do not park in the bike lane.

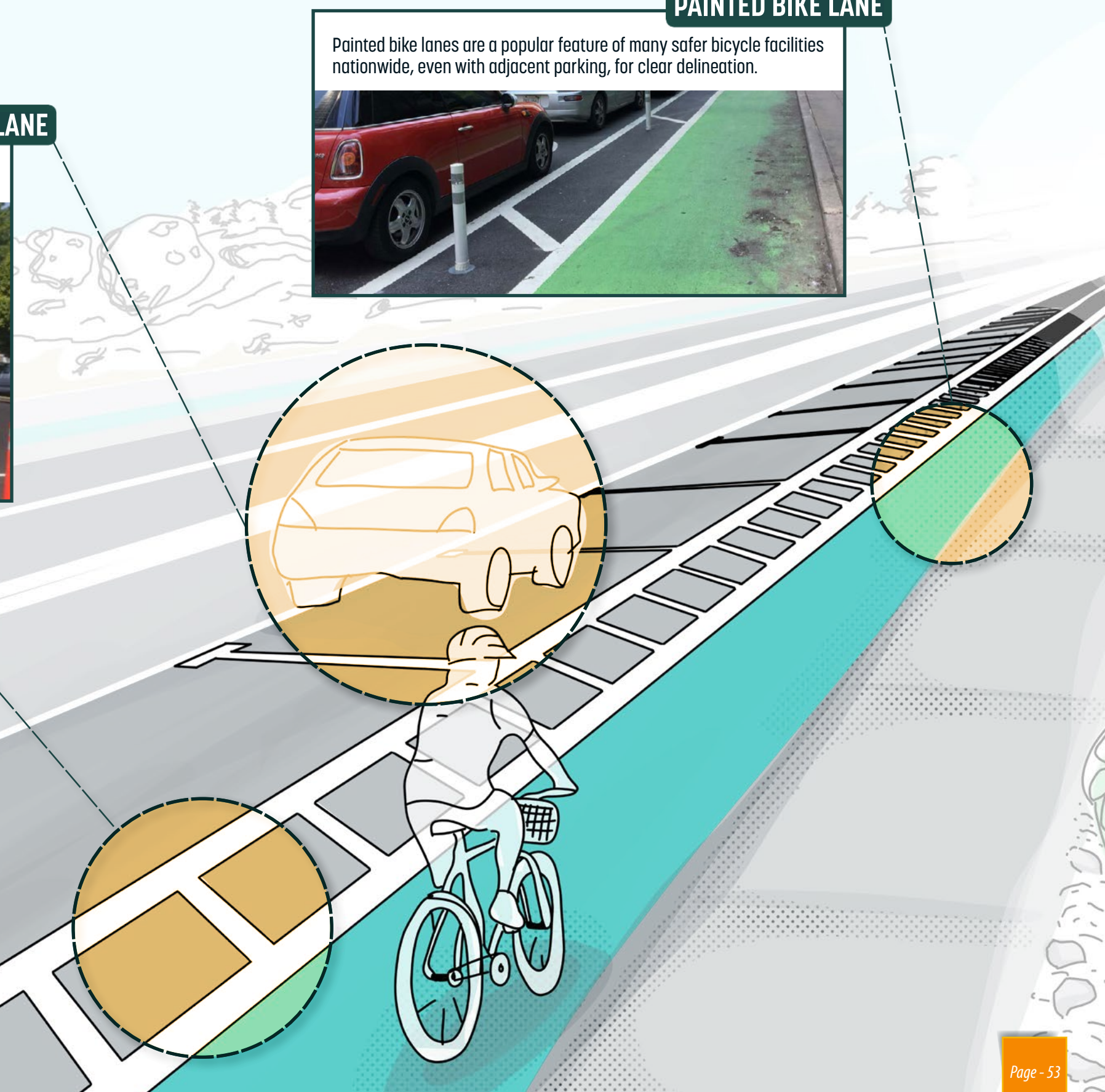

## CURB STOPS

ALSO KNOWN AS: PARKING STOPS, PARKING BLOCKS, WHEEL STOPS.

Curb stops are low, linear barriers commonly found at the front of parking spaces in parking lots. They are widely used in cities and have become a popular method for creating safer bicycle facilities. Made from durable materials such as concrete, rubber, or recycled plastic, curb stops are **highly resilient and offer a cost-effective alternative** to more permanent infrastructure. Their modular design allows them to form long, continuous buffers between bike lanes and vehicle traffic, enhancing cyclist safety by providing a physical barrier. While less expensive than curbs or other permanent solutions, curb stops still offer a significant level of protection, making them a practical option for urban bike lane design.

FIGURE: 17. CURB STOPS DIMENSIONAL STANDARDS

<b>Bike Lane Width</b>	5' - 6' typically, or more.
<b>Buffer Width</b>	2'
<b>Stops Spacing</b>	6' typically, or less.
<b>Stops Dimensions</b>	Typically 6' x 1'-2' x 4"

FIGURE: 19. CURB STOPS STRENGTH + WEAKNESSES

<b>Strengths</b>	<ul style="list-style-type: none"> <li>Provides strong protection against vehicle encroachment.</li> <li>Long-lasting and able to withstand impacts from vehicles.</li> <li>Visually and physically separates bike lanes from vehicle traffic.</li> <li>Helps slow down vehicle speeds by narrowing the road space.</li> <li>Requires less frequent maintenance compared to flexible barriers or painted buffers.</li> <li>Performs well in all weather conditions, including snow.</li> </ul>
<b>Weaknesses</b>	<ul style="list-style-type: none"> <li>More expensive to install than painted buffers or bollards.</li> <li>Difficult and costly to modify or remove once installed.</li> <li>If improperly designed, can cause accidents if cyclists hit them.</li> <li>May block water flow, leading to puddles or drainage problems in the bike lane or street.</li> <li>Limits access for emergency, service, and delivery vehicles unless designed to accommodate them.</li> <li>Can complicate snowplowing and other road maintenance operations unless designed to accommodate them.</li> </ul>

FIGURE: 18. CURB STOPS

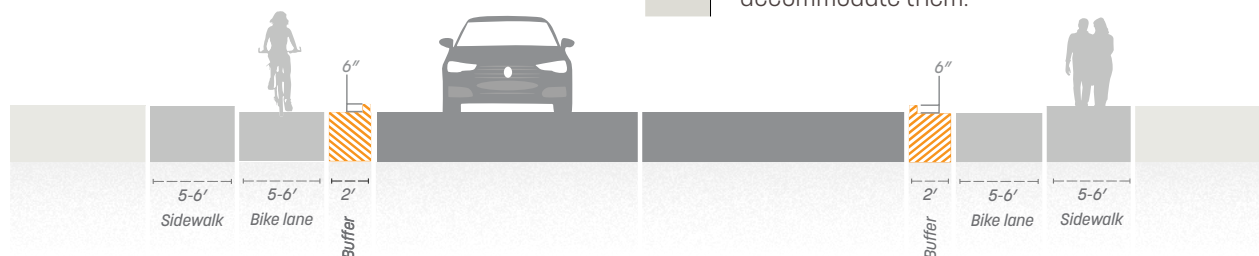

### CURB STOPS PRECEDENT IMAGERY

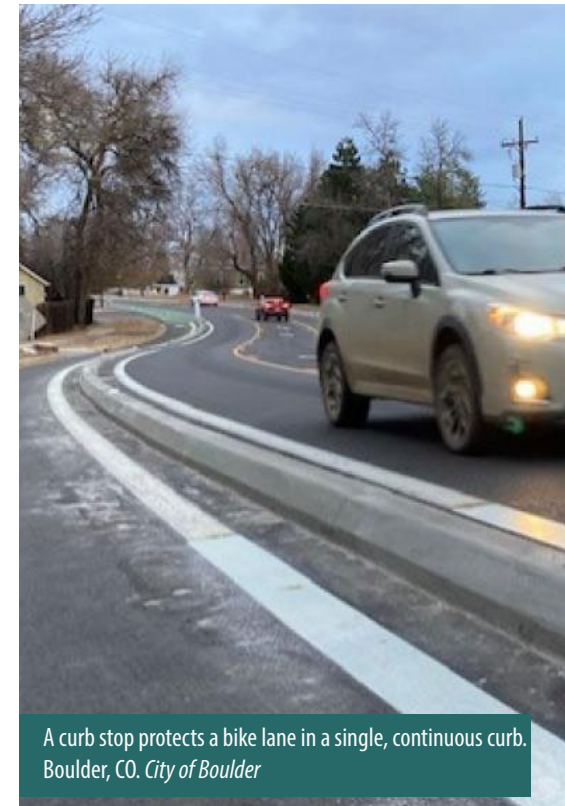

A curb stop protects a bike lane in a single, continuous curb. Boulder, CO. *City of Boulder*



Curb stops are made more visible by the occasional plastic post, in Denver, CO. *Esteban L. Hernandez, Axios*



A taller model of curb stops provide greater visibility on a wide buffer, painted by a local artist. Boulder, CO. *City of Boulder*



Curb stops are made visible with infrequent flex posts in Boulder, CO. *City of Boulder*

## Curb Stops Design Strategies

Curb stops are a common feature in urban infrastructure, offering an affordable and low-impact solution for bike lane protection. While traditional concrete curb stops have a standardized shape, their flat surfaces can be customized with various color schemes or patterns, potentially involving artists or community partners to enhance their visual appeal. Larger concrete barriers, which offer greater flexibility in shape and design, can further elevate the aesthetic character of streets. For example, in Boulder, CO, medium-sized concrete barriers were selected over curb stops, providing a more substantial physical barrier that was also used as a canvas for public art in collaboration with local artists.

The minimal impact of installing a protected bike lane with curb stops is demonstrated on Yucca Street. The existing 6-foot bike lane already exceeds the minimum width for bike lanes on collector streets. A 2-foot buffer in each direction can be easily integrated to add protection by reducing the 16-foot wide turning lane to 12 feet, which remains above the minimum 11-foot travel lane standard. This adjustment provides sufficient space for the installation of curb stops, enhancing the safety of the bike facility through increased visibility and physical protection while maintaining the functionality of the roadway.

**FIGURE: 20. DIMENSIONAL STANDARDS**

<b>Bike Lane Width</b>	5' - 6' typically, or more.
<b>Buffer Width</b>	Min. 1.5' - 2'
<b>Stops Spacing</b>	6' typically, or less.
<b>Stops Dimensions</b>	Typically 6' x 1'-2' x 4"

**FIGURE: 21. HIGH-LEVEL COST ESTIMATE + MAINTENANCE NEEDS**

<b>Retrofit Cost Estimate</b>	<b>\$30 - \$50 linear foot</b> (Involves placing stops on existing roadways, may require minor surface prep)
<b>New Construction Cost Estimate:</b>	<b>\$40 - \$70 per linear foot</b> (Installation during road construction with a higher focus on design integration)
<b>Maintenance Requirements:</b>	Occasional inspections for cracks or displacement, regular cleaning.
<b>Annual Maintenance Cost:</b>	\$1 - \$3 per linear foot

*\*This high-level cost estimate provides a general guide based on typical industry standards but may vary significantly due to factors like local costs, site conditions, design preferences, and regulatory requirements, and should not be considered a definitive projection without detailed assessment.*

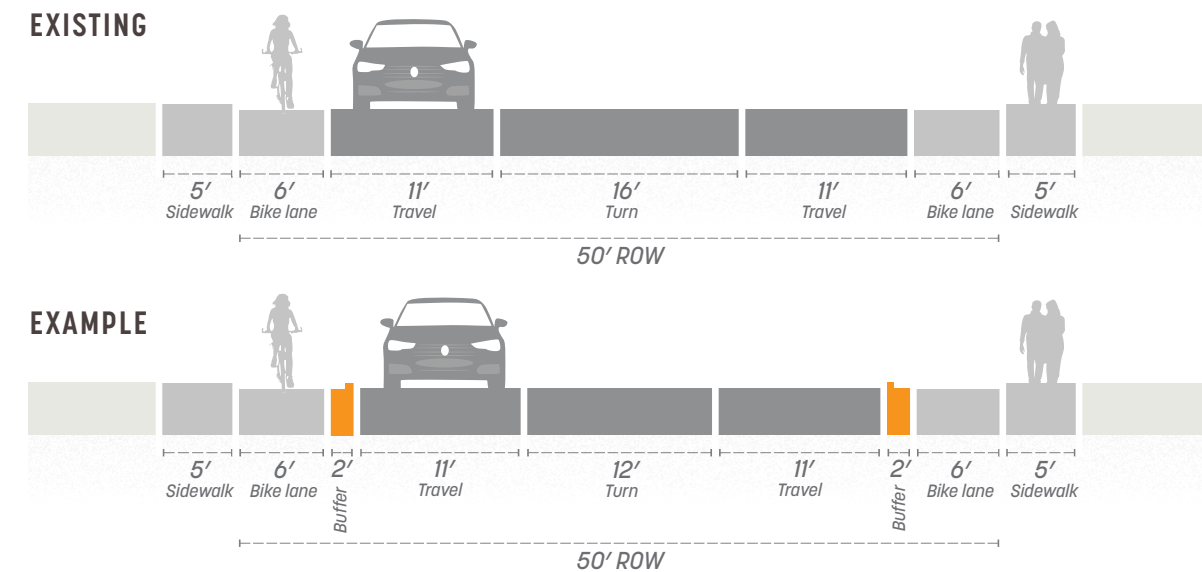
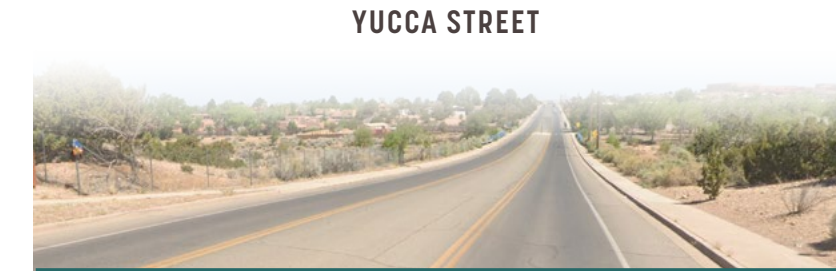

### A WORD FROM AASHTO:

AASHTO recommends bike lane widths based on bicycle traffic volume and the presence of curbs. When curb stops are used, the bike lane is adjacent to two curbs—the sidewalk and a concrete curb or barrier. **The recommended widths for a one-way separated bike lane between curbs are:**

Peak Hour Directional Bicyclist Volume	One-Way Separated Bike Lane Width (Adjacent to One Vertical Curb) (ft.)	Street Buffer Zone
Minimum	4'	-
< 150	6.5' - 8.5'	6'*
150 - 750	8.5' - 10'	
> 750	≥ 10'	

*\*Wider buffers are recommended for multi-lane roads with speed limits over 35 mph*

- ✓ Recommended for locations on bridges or roadways with posted speed over 40 mph or where buffer widths are less than the recommended widths.
- ✓ Crash cushions may be needed at barriers ends based on roadway speeds, clear zone requirements, and proximity to travel lanes.
- ✓ Barriers should be discontinued on approaches to motorists crossings of bike lanes and at crosswalks if they will restrict sight lines between users.
- ✓ Continuous barriers should account for drainage and include breaks to ensure proper function.
- ✓ Curb stops must fully fit within the buffer.

## Curb Stops Design Elements

### CURB STOP

Curb stops are made from durable materials such as concrete, rubber, or recycled plastic, are highly resilient, and offer a cost-effective alternative to more permanent infrastructure. Boulder, CO, installed higher-profile curb stops, providing more comfort for users and a surface for public art.



### CONTINUOUS CURB

The continuous curb provides a high level of separation and comfort. This curb can be absent near driveways and intersections.



### PAINTED BIKE LANE

Painted bike lanes are a popular feature of many safer bicycle facilities

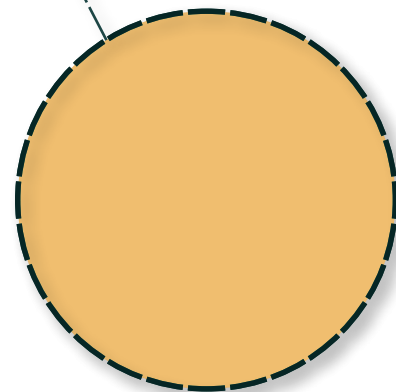
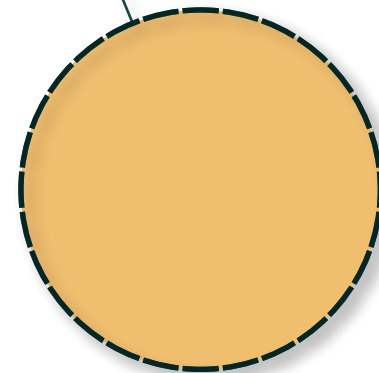
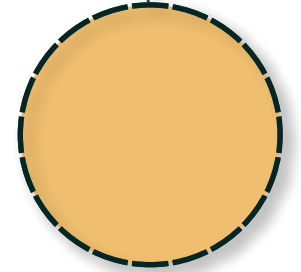

# PLANTERS

Planters can be permanent or non-permanent and placed continuously in the buffer zone adjacent to a bike lane, providing highly visible and durable protection from moving traffic. Planters also add an aesthetic element to the streetscape. Planters have the **most variable design of any safer bike facility**, with lots of room for municipalities to decide the style, size, and contents of the planters. Whether it's large pots spaced out, or a long concrete planter that provides a continuous curb, planters that protect a bike lane also add aesthetic value to the street for all users.

**FIGURE: 22. PLANTERS DIMENSIONAL STANDARDS**

<b>Bike Lane Width</b>	5' - 6' typically, or more.
<b>Buffer Width</b>	4'
<b>Planter Spacing</b>	Variable
<b>Planter Dimensions</b>	Variable. Typically 3' wide (FHWA) and 28" - 36" tall (Seattle ROW Manual)

**FIGURE: 24. PLANTERS STRENGTH + WEAKNESSES**

- |                   |   |
|-------------------|---|
| <b>Strengths</b>  | <ul style="list-style-type: none"> <li>▶ Provides solid, consistent protection between cyclists and vehicle traffic.</li> <li>▶ Enhances the visual appeal of streetscapes, contributing to a more pleasant urban environment.</li> <li>▶ Visually narrows the road, encouraging slower vehicle speeds.</li> <li>▶ Can contribute to urban greenery, helping with stormwater management and air quality.</li> <li>▶ Offers opportunities for community involvement in maintaining plants and greenery.</li> </ul>                       |
| <b>Weaknesses</b> | <ul style="list-style-type: none"> <li>▶ Requires regular upkeep for the plants, including watering, trimming, and replacing dead plants.</li> <li>▶ Planters take up more space compared to other buffer types, which may limit their use on narrow roads.</li> <li>▶ Debris, dirt, or leaves from the planters can spill into the bike lane, creating hazards for cyclists.</li> <li>▶ Planters may be damaged by vehicles, requiring costly repairs or replacements.</li> <li>▶ Higher installation and maintenance cost.</li> </ul> |

**FIGURE: 23. PLANTERS SECTION**

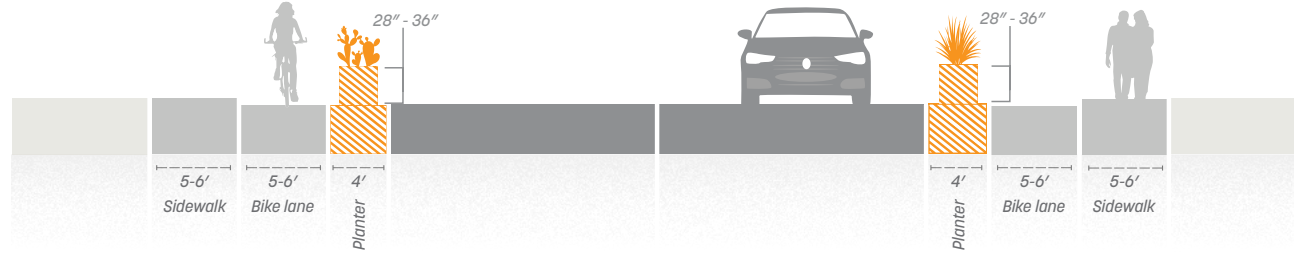

## PLANTERS PRECEDENT IMAGERY



## Planters Design Strategies

Planter boxes in the buffer zone of bike lanes provide both protection from traffic and aesthetic value. Whether as spaced large pots or continuous concrete barriers, they create visible, durable separations for cyclists while enhancing the streetscape.

Highly customizable, planters allow for flexibility in style, size, and materials. Low-cost options made from recycled plastic or fiberglass offer durability, weather resistance, and easy installation. Higher-quality designs, such as tightly spaced metal planters, can provide added protection and amenities like footrests at intersections.

In city centers, larger concrete or terracotta planters complement Santa Fe's unique aesthetic, especially where slower traffic allows for more decorative designs, benefiting both cyclists and pedestrians.

**FIGURE: 25. DIMENSIONAL STANDARDS**

<b>Bike Lane Width</b>	5' - 6' typically, or more.
<b>Buffer Width</b>	4' or more.
<b>Planter Spacing</b>	Variable
<b>Planter Dimensions</b>	Variable. Typically 3' wide (FHWA) and 28" - 36" tall (Seattle ROW Manual)

### A WORD FROM AASHTO:

AASHTO recommends bike lane widths based on bicycle traffic volume and the presence of curbs. When planters are used, the bike lane may be adjacent to two curbs—the sidewalk and the planter element. **The recommended widths for a one-way separated bike lane between curbs are:**

Peak Hour Directional Bicyclist Volume	One-Way Separated Bike Lane Width (Adjacent to One Vertical Curb) (ft.)	Street Buffer Zone
Minimum	4'	-
< 150	6.5' - 8.5'	6'*
150 - 750	8.5' - 10'	
> 750	≥ 10'	

\*Wider buffers are recommended for multi-lane roads with speed limits over 35 mph

**FIGURE: 26. HIGH-LEVEL COST ESTIMATE + MAINTENANCE NEEDS**

<b>Retrofit Cost Estimate</b>	<b>\$50 - \$100 linear foot</b> (Adding planters to existing roads, with minimal disruption)
<b>New Construction Cost Estimate:</b>	<b>\$120 - \$200</b> per linear foot (Installing planters during road construction, with design customization.)
<b>Maintenance Requirements:</b>	Plant care (watering, trimming), cleaning debris.
<b>Annual Maintenance Cost:</b>	\$10 - \$20 per linear foot

*\*This high-level cost estimate provides a general guide based on typical industry standards but may vary significantly due to factors like local costs, site conditions, design preferences, and regulatory requirements, and should not be considered a definitive projection without detailed assessment.*

- ✓ Spaced planters are not appropriate along roadways with posted speed limits of 35 mph or greater.
- ✓ Planters constructed on roadways with posted speeds of 30 mph, they should be constructed of a durable material. The planter should not be anchored to the pavement.
- ✓ Planters should be supplemented by pavement markings to delineate the street buffer zone.
- ✓ Buffer width may be different in lower-speed urban areas and suburban communities.
- ✓ Planters can be closely spaced or designed as a linear feature for near-continuous vertical separation.
- ✓ Continuous barriers should account for drainage and include breaks to ensure proper function.
- ✓ Planters stops must fully fit within the buffer.
- ✓ Where space is constrained and shy distance to the planter must be eliminated, the shy distance should be equivalent to the planter.

**YUCCA STREET**



**EXISTING**

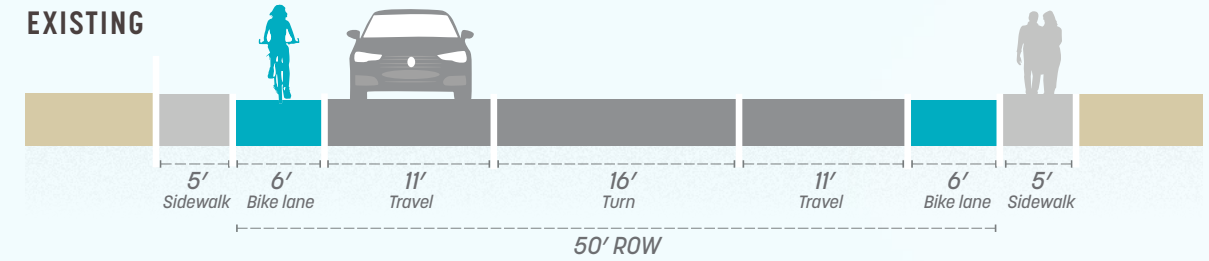

**EXAMPLE**

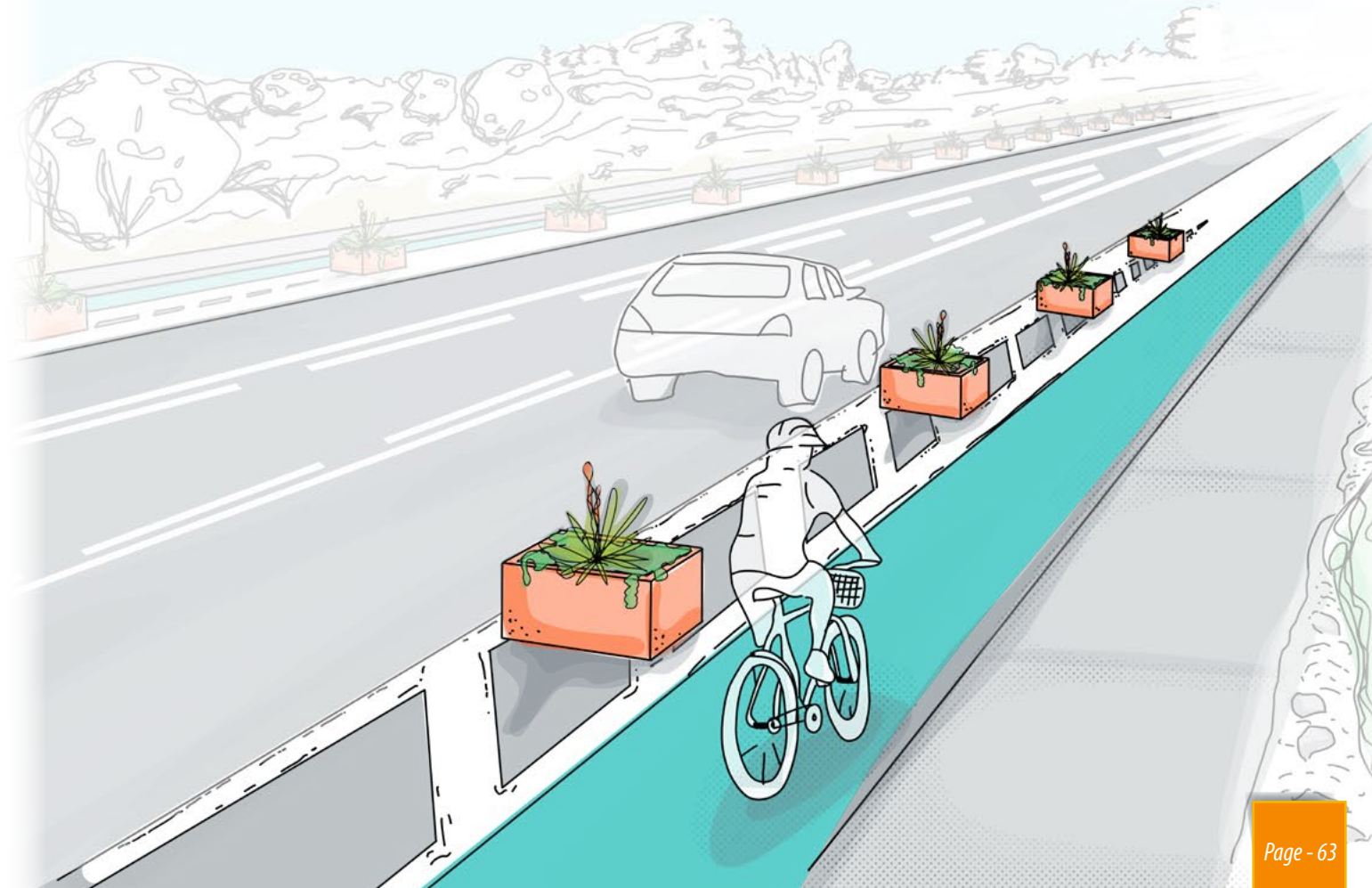
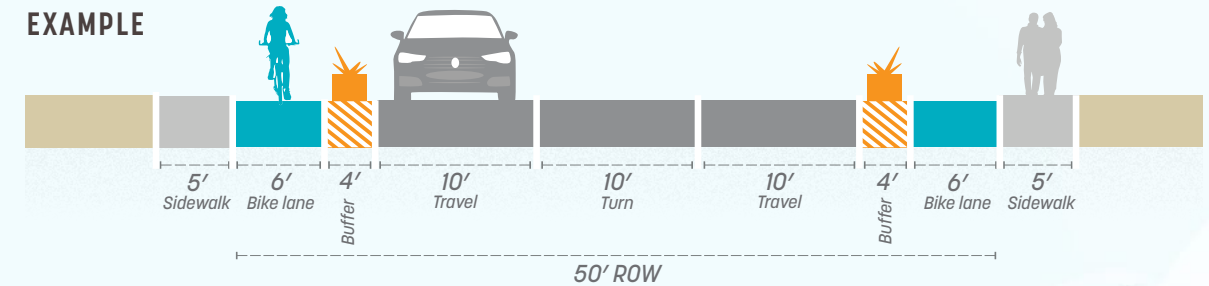

## Planters Design Elements

### PLANTERS

Planters allow for a variety of aesthetic decisions, including the size, shape, color, material, and content of the landscaping. Flat surfaces also provide more opportunities for community design.



### PAINTED BIKE LANE

Painted bike lanes are a popular feature of many safer bicycle facilities nationwide.



### THERMOPLASTIC PAINT

No matter the planter type, a painted buffer is typically present as well to ensure the lanes are clearly delineated throughout.

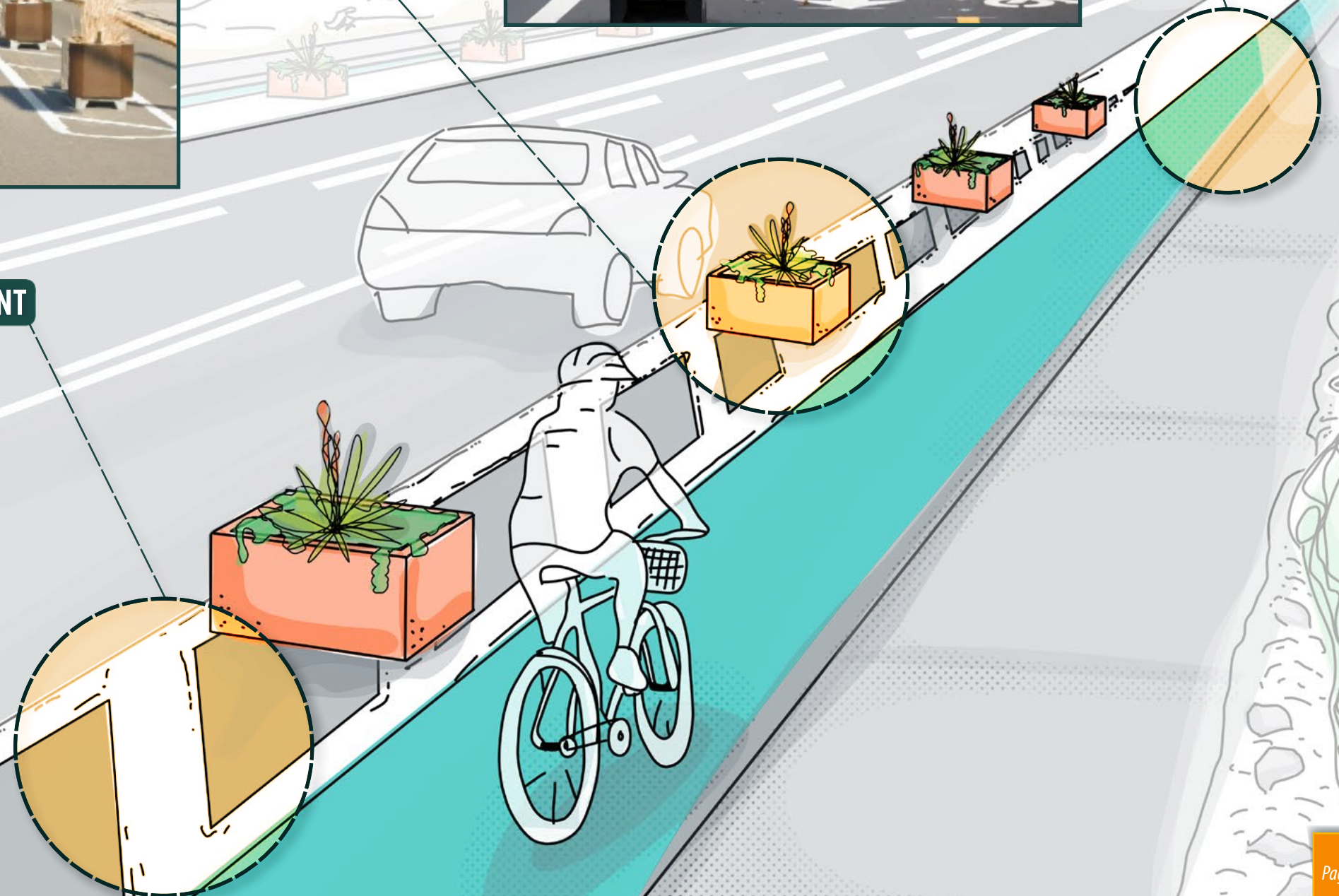

## RAISED MEDIAN

### ALSO KNOWN AS RAISED ISLAND

Raised medians, typically made from concrete, offer a secure and visually appealing buffer for bike lanes. Unlike intermittent barriers such as planters or posts, **raised medians provide continuous, linear protection**, offering cyclists a higher level of safety. This design is especially **effective in attracting “interested but concerned” cyclists** by creating a robust physical barrier from traffic. Raised medians also enhance streetscapes, with options to complement local materials, styles, and colors, such as in Santa Fe.

Designs can vary from simple concrete curbs to wider medians with decorative elements or landscaping. Whether cast in place or pre-cast, raised medians are **more durable** than alternatives like plastic posts or curb stops, **requiring less maintenance over time**. Although they involve a higher initial cost, their long-term durability and reduced upkeep make them a cost-effective option. Additionally, they contribute to traffic calming, narrowing the roadway and improving safety for all users.

FIGURE: 27. RAISED MEDIANS DIMENSIONAL STANDARDS

<b>Bike Lane Width</b>	5' - 6' typically, or more.
<b>Median Width</b>	16" minimum (FHWA)
<b>Median Height</b>	6" typically
<b>Median Features</b>	Continuous, potentially broken up by planting strips or drainage gaps.

FIGURE: 29. RAISED MEDIANS STRENGTH + WEAKNESSES

<b>Strengths</b>	<ul style="list-style-type: none"> <li>Provides strong, physical separation between cyclists and vehicle traffic, offering maximum safety.</li> <li>Narrower roadways created by raised medians encourage slower vehicle speeds.</li> <li>Long-lasting infrastructure that requires minimal maintenance once constructed.</li> <li>Can also serve as a refuge for pedestrians at crossings, enhancing overall street safety.</li> <li>Can be landscaped to improve the visual appeal of the roadway and contribute to environmental benefits like stormwater management.</li> </ul>
<b>Weaknesses</b>	<ul style="list-style-type: none"> <li>More expensive and time-consuming to construct compared to other buffering options.</li> <li>Requires additional road width, limiting its use on narrower streets.</li> <li>While durable, landscaped medians may require periodic upkeep, such as trimming and cleaning.</li> <li>Can make access for emergency vehicles, deliveries, or turning movements more difficult.</li> <li>Permanent and difficult to modify or reconfigure once installed, reducing adaptability to changing street needs.</li> </ul>

FIGURE: 28. RAISED MEDIAN SECTION

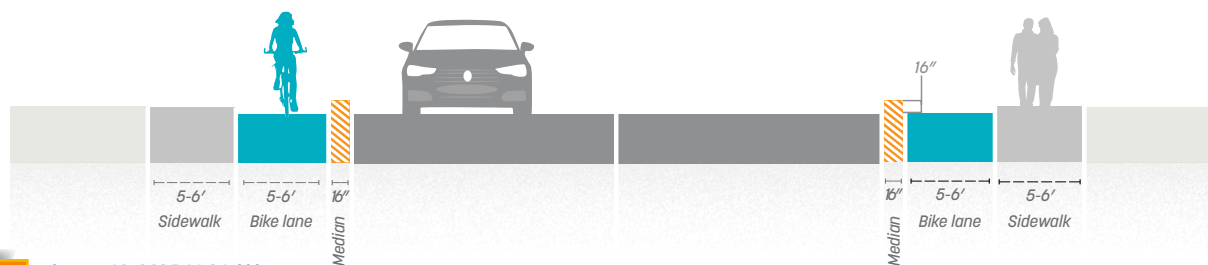

August 19, 2025 11:31 AM

### RAISED MEDIAN PRECEDENT IMAGERY



## Raised Median Design Strategies

Raised medians, often constructed as concrete curbs, provide an attractive, secure bike facility with minimal long-term maintenance. Unlike planters or posts spaced intermittently, a raised median forms a continuous, linear barrier that enhances safety more effectively. This design is especially valuable for encouraging cycling among most Americans who express interest but have safety concerns.

At their simplest, raised medians can consist of a continuous concrete curb, as seen in Tucson, AZ. However, beyond this minimal design, raised medians offer **extensive opportunities for customization**, such as designs that to **reflect the unique character of Santa Fe** or specific streetscapes. For example, different paver shapes, colors, and sizes can be embedded within the median. Decorative elements such as ceramic or iron accents can add flair that aligns with Santa Fe's style. Additionally, a wider median could incorporate stormwater drainage features or small-scale landscaping, allowing for a creative and innovative approach to urban design.

**FIGURE: 30. DIMENSIONAL STANDARDS**

<b>Bike Lane Width</b>	5' - 6' typically, or more.
<b>Median Width</b>	16" minimum (FHWA)
<b>Median Height</b>	6" typically
<b>Median Features</b>	Continuous, potentially broken up by planting strips or drainage gaps.

**FIGURE: 31. HIGH-LEVEL COST ESTIMATE + MAINTENANCE NEEDS**

<b>Retrofit Cost Estimate</b>	<b>\$60 - \$120 linear foot</b> (Installation of raised medians on existing roads, potentially disrupting traffic flow)
<b>New Construction Cost Estimate:</b>	<b>\$150 - \$300</b> per linear foot (Integrating raised medians into the initial road design for stronger protection)
<b>Maintenance Requirements:</b>	Minimal for plain medians, higher if landscaped (trimming, cleaning)
<b>Annual Maintenance Cost:</b>	\$5 - \$15 per linear foot

*\*This high-level cost estimate provides a general guide based on typical industry standards but may vary significantly due to factors like local costs, site conditions, design preferences, and regulatory requirements, and should not be considered a definitive projection without detailed assessment.*

### A WORD FROM AASHTO:

AASHTO recommends bike lane widths based on bicycle traffic volume and the presence of curbs. When a raised median is present, the bike lane may be bordered by both the sidewalk and the median. **The recommended widths for a one-way separated bike lane between curbs are:**

Peak Hour Directional Bicyclist Volume	One-Way Separated Bike Lane Width (Between Vertical Curbs) (ft.)	Street Buffer Zone
Minimum	4.5'	-
< 150	6.5' - 8.5'	6'*
150 - 750	8.5' - 10'	
> 750	≥ 10'	

*\*Wider buffers are recommended for multi-lane roads with speed limits over 35 mph*

- ✓ Raised medians may be used to channelize stormwater.
- ✓ Raised medians are typically continuous, but should incorporate considerations for drainage and stormwater in their design.
- ✓ Mountable curbs are an option where emergency vehicles access is needed.
- ✓ They are appropriate design solutions for roadways over 45 mph.
- ✓ Raised medians are recommended on bridges or along roadways with posted speeds over 40 mph.
- ✓ Crash cushions may be needed at barrier ends based on roadway speeds, clear zone requirements, and proximity to travel lanes.

**YUCCA STREET**



**EXISTING**

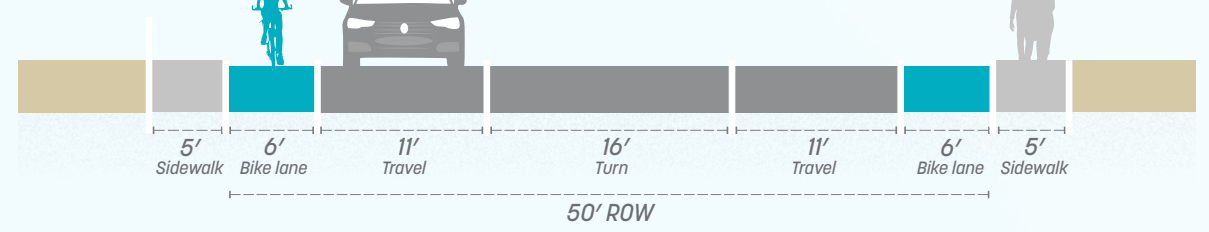

**EXAMPLE**

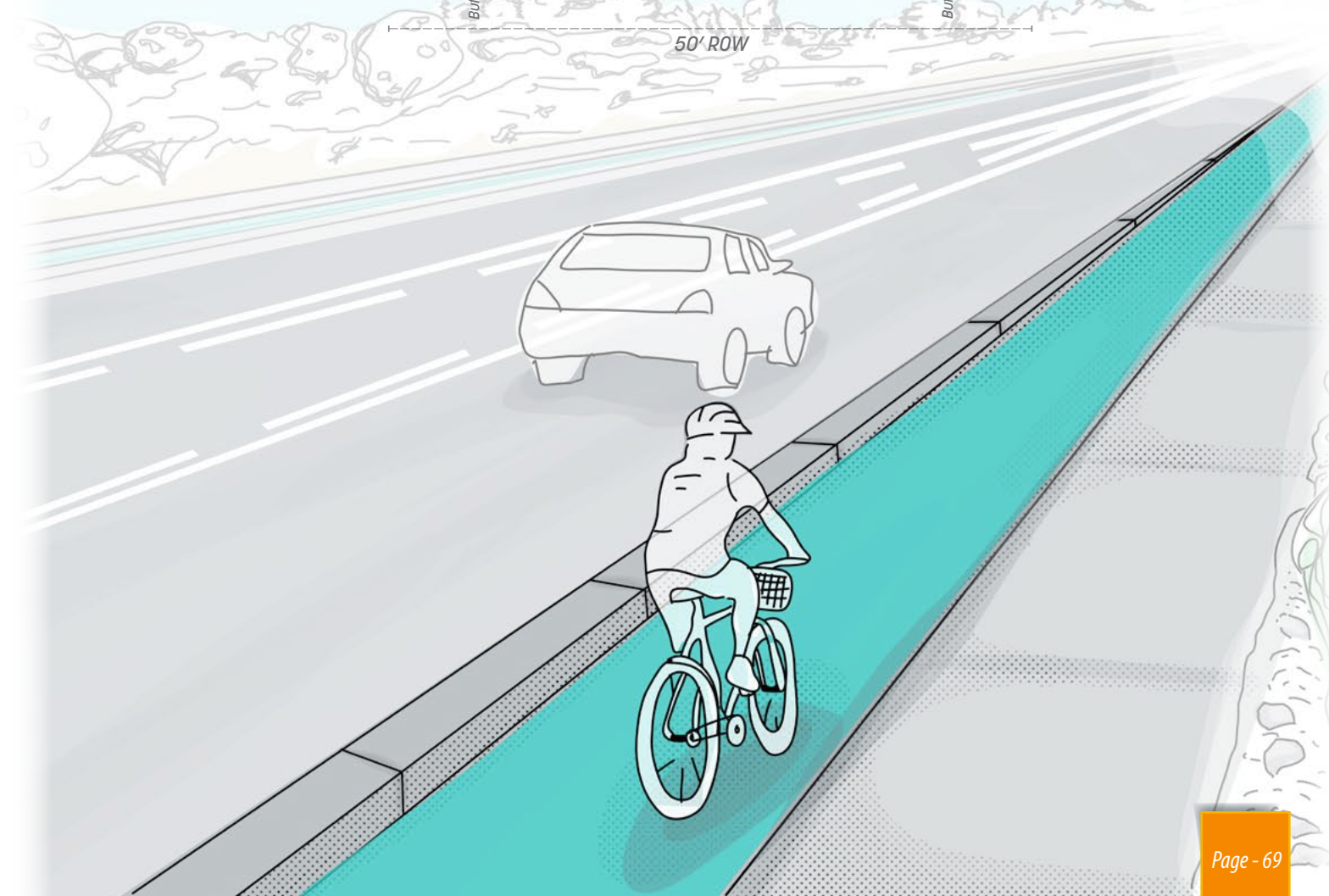
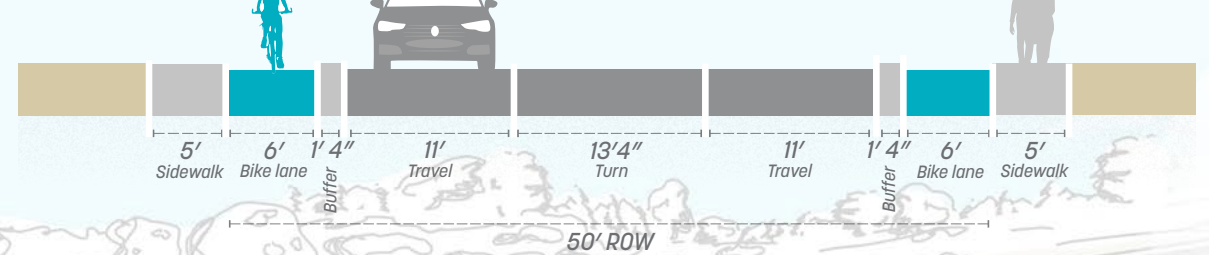

## Raised Median Design Elements

### RAISED MEDIAN

A raised median can be customized with a variety of materials, widths, and landscaping



### PAINTED BIKE LANE

Painted bike lanes are a popular feature of many safer bicycle facilities across the nation, even in median bike lanes for true delineation.



### CONTINUOUS CURB

The raised medium provides a high level of separation and comfort. The median can accommodate driveways and intersections by creating gaps.

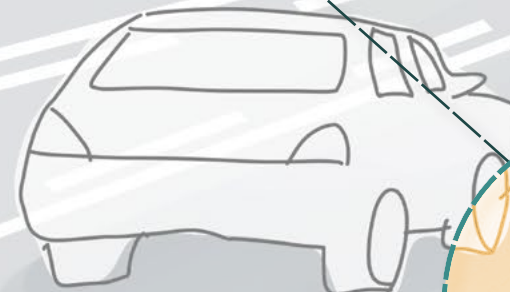
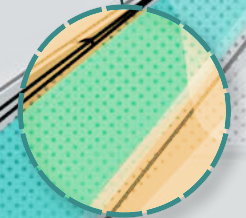
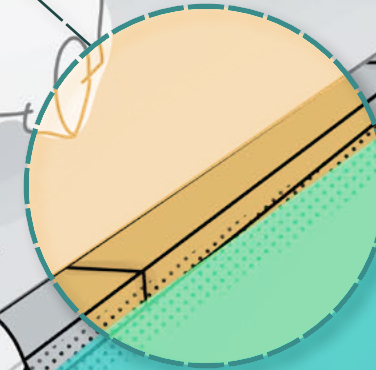
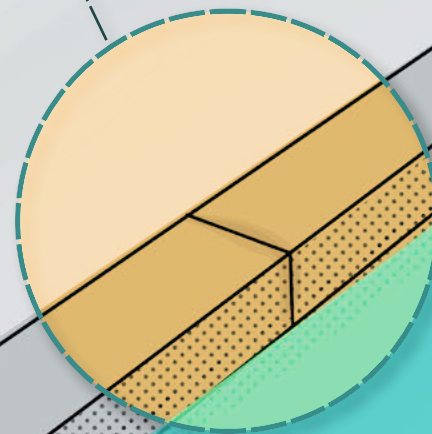

## RAISED BIKE LANE

ALSO KNOWN AS SHARED USE PATH, SIDEPATH, CYCLETRACK.

Raised bike lanes, also known as cycle tracks, are a type of bicycle facility that offers **full separation from vehicle traffic by elevating the bike lane to a different grade**—either at sidewalk level or at an intermediate height between the street and the sidewalk. This design provides a high level of safety and comfort for cyclists by creating a clear physical barrier from motor vehicles and pedestrian encroachment in the bike lane, and vice-versa.

When raised to sidewalk level, it is essential to use different pavement types, textures, or markings to **clearly delineate the bike lane from pedestrian zones**, ensuring both cyclists and pedestrians have their own dedicated space. In addition to the elevation, a buffer is often placed between the bike lane and the roadway. This buffer may consist of matching sidewalk pavement, landscaping, or other decorative elements that further enhance safety and visual appeal. Raised bike lanes not only improve cyclist protection but also contribute to a more organized and attractive streetscape.

This design requires careful planning for drainage and accessibility, as well as a larger upfront investment, but the long-term benefits in terms of safety, user comfort, and reduced maintenance make raised bike lanes worthy of serious consideration.

FIGURE: 32. RAISED BIKE LANE DIMENSIONAL STANDARDS

<b>Bike Lane Width</b>	5' - 6' typically
<b>Buffer Width</b>	2' minimum between bike lane and street.
<b>Raised Height</b>	3"-6" typically, or at grade with sidewalk.

FIGURE: 34. RAISED BIKE LANE STRENGTH + WEAKNESSES

<b>Strengths</b>	▸ Physically separates cyclists from vehicles, providing maximum safety.
	▸ Often includes separation from both vehicle lanes and sidewalks, reducing conflicts with pedestrians.
	▸ Cyclists are more visible to drivers due to the raised elevation.
	▸ Provides a smooth, designated space that enhances rider comfort and confidence.
	▸ Integrates well into streetscapes and can be designed to complement surrounding infrastructure.
<b>Weaknesses</b>	▸ Typically constructed with materials like concrete or asphalt, making them low-maintenance and long-lasting.
	▸ Requires significant investment in construction compared to simpler buffer methods.
	▸ Demands more road space, which can be a challenge on narrower streets.
	▸ Difficult to retrofit: complex and costly to modify or install on existing roadways.

FIGURE: 33. RAISED BIKE LANE SECTION

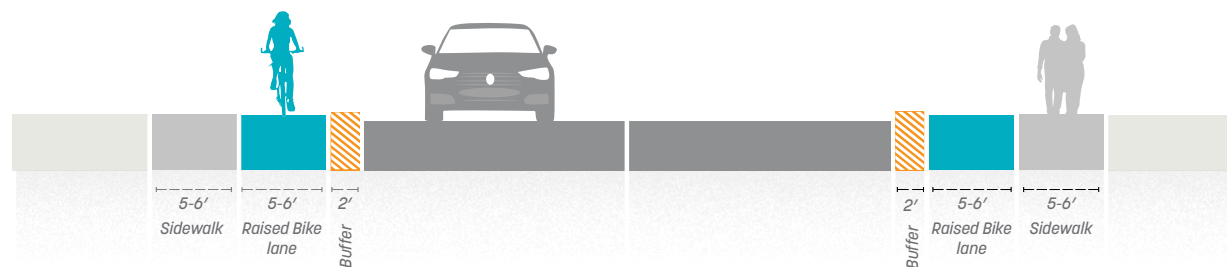

## RAISED BIKE LANE PRECEDENT IMAGERY

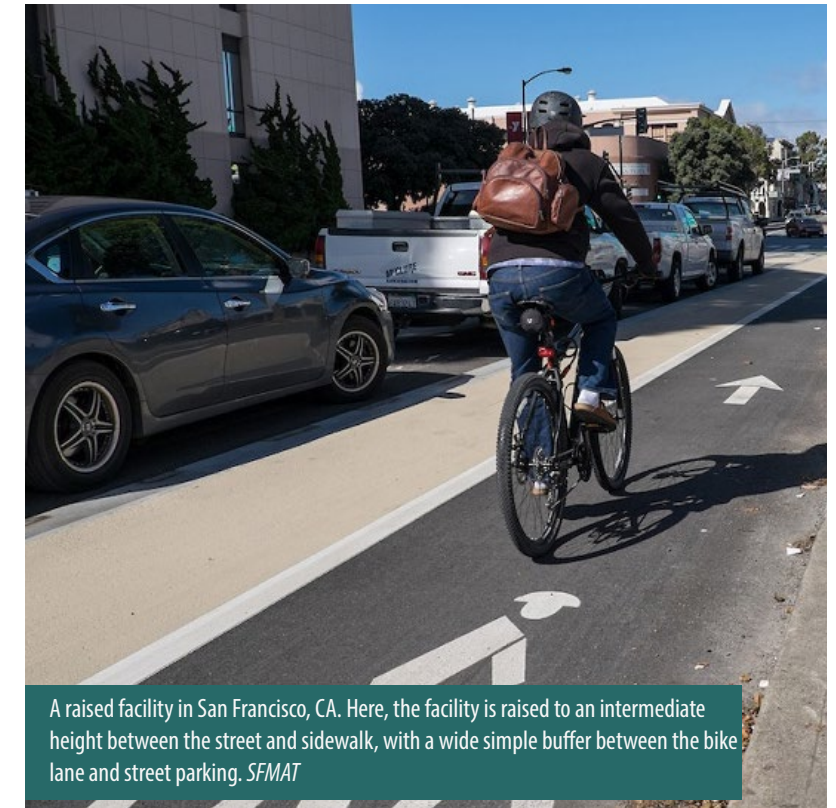

## Raised Bike Lane Design Strategies

Raised bike lanes offer versatile design options that can be tailored to various urban contexts, safety requirements, and aesthetic goals. These elevated paths provide cyclists with a safe, dedicated space, typically separated from vehicle traffic by curbs or landscaped buffers. The height of the bike lane can vary, with some designs positioned just slightly above road level while others align with the sidewalk to create a more pronounced elevation. Surface materials may include smooth asphalt or permeable paving, incorporating sustainable features like water drainage.

Some raised bike lanes are integrated with pedestrian paths, using distinct textures or markings to differentiate the bike lane, while others maintain a clear physical separation. Additional design elements such as lighting, signage, and curb treatments enhance visibility and usability, adapting to local contexts and traffic conditions. These design variations balance functionality, safety, and seamless integration within the broader urban landscape.

**FIGURE: 35. DIMENSIONAL STANDARDS**

<b>Bike Lane Width</b>	5' - 6' typically
<b>Buffer Width</b>	2' minimum between bike lane and street.
<b>Raised Height</b>	3"-6" typically, or at grade with sidewalk.
<b>Median Features</b>	Continuous, potentially broken up by planting strips or drainage gaps.

**FIGURE: 36. HIGH-LEVEL COST ESTIMATE + MAINTENANCE NEEDS**

<b>Retrofit Cost Estimate</b>	<b>\$200 - \$350 linear foot</b> (Requires regrading and significant modification of the existing roadway)
<b>New Construction Cost Estimate:</b>	<b>\$300 - \$500</b> per linear foot (Full integration of the raised bike lane during road construction)
<b>Maintenance Requirements:</b>	Minimal long-term, but regular sweeping, snow removal, occasional resurfacing.
<b>Annual Maintenance Cost:</b>	\$2 - \$4 per linear foot

*\*This high-level cost estimate provides a general guide based on typical industry standards but may vary significantly due to factors like local costs, site conditions, design preferences, and regulatory requirements, and should not be considered a definitive projection without detailed assessment.*

### A WORD FROM AASHTO:

AASHTO recommends bike lane widths based on bicycle traffic volume and the presence of curbs. When a raised bike lane is present, the bike lane may be adjacent to the sidewalk and grade repaved from the travel lane. **The recommended widths for a one-way separated bike lane between curbs are:**

Peak Hour Directional Bicyclist Volume	One-way Bike Lane Width (ft) At Sidewalk Level
Minimum	5'
Lower Limit	6.5'
Upper Limit	8'
Maximum	10'

- ✓ Consider adding mountable curb to allow bicyclist to navigate between the street and the bike lane.
- ✓ Consider a vertical curb of 6"-8" where motorist encroachment into the bike lane is discouraged.
- ✓ At intersections, raised bike lanes can transition to standard street-level bike lanes.
- ✓ To distinguish the bike lane from the sidewalk, use at least two elements such as contrasting paving, green pavement, a white edge line by the curb, or directional indicators.
- ✓ To distinguish the bike lane from the travel lane, use at least two elements such as bike lane regulatory signs, contrasting pavement materials, or green-colored pavement.

## YUCCA STREET



### EXISTING

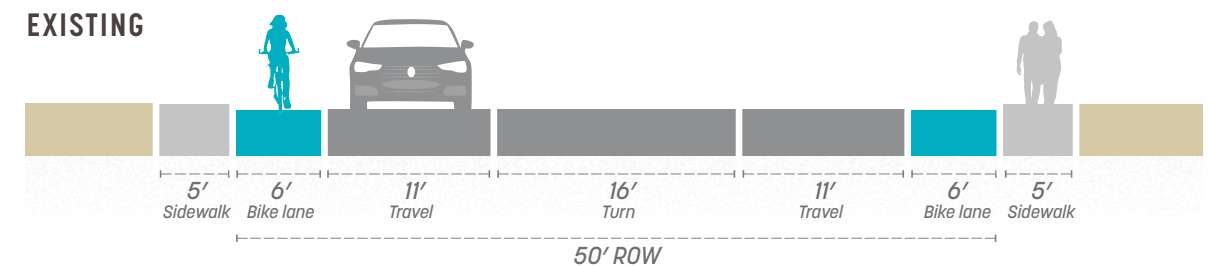

### EXAMPLE

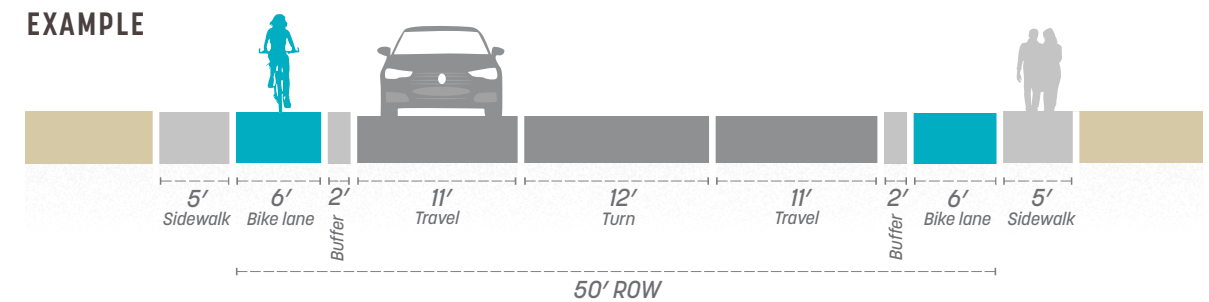

## Raised Bike Lane Design Elements

### RAISED LANE

Raised bike lanes have various design options. They can be at sidewalk level or immediately between the travel lane and the sidewalk. Different materials, colors, and buffer widths make this a very customizable option that fits in the space and matches the street's design.



### BUFFER FROM STREET

Buffers can be as simple as a concrete curb and offer opportunities for more aesthetic decisions, like interesting materials or colors.



### PAINTED BIKE LANE

Painted bike lanes are a popular feature of many safer bicycle facilities nationwide, even in raised bike lanes for proper delineation.

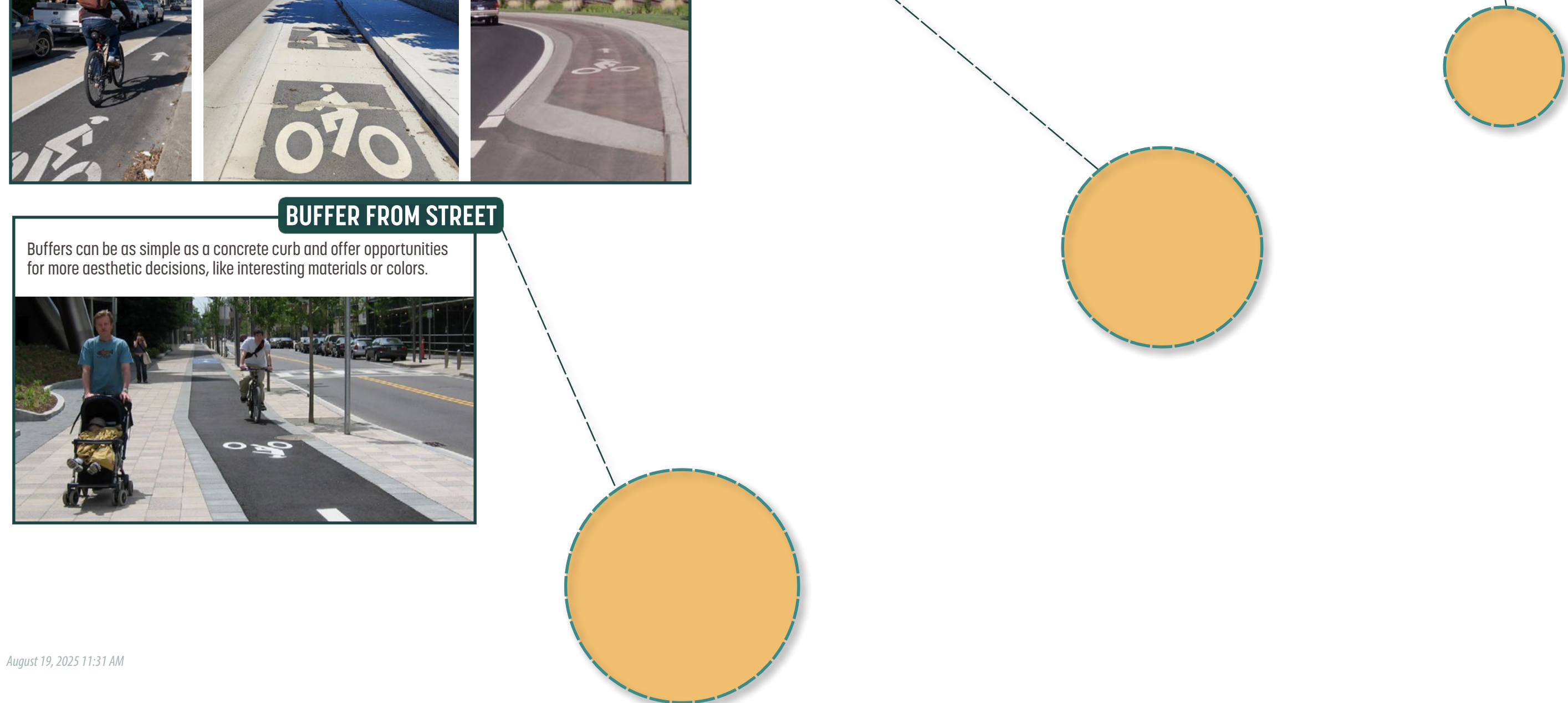

## WHEN SHOULD A SAFER BICYCLE FACILITY BE PRIORITIZED

Safer bicycle facilities are essential when cyclist safety and comfort demand enhanced separation from motor vehicle traffic. They are particularly necessary **where vehicle speeds consistently exceed 25 mph**. Such conditions increase the risk and severity of collisions, making it crucial to ensure cyclist safety. Additionally, **roads with average daily traffic (ADT) greater than 7,000 per day** may require safer bicycle facilities to minimize potential conflicts between vehicles and cyclists. In mixed-use or high-pedestrian areas, safer bicycle lanes help manage interactions among cyclists, pedestrians, and vehicles, thus creating a safer and more organized environment.

Locations with **high existing or anticipated bicycle usage**—such as **near schools, transit hubs, commercial centers, or popular destinations**—often warrant the inclusion of protected lanes to accommodate and encourage safe cycling. These facilities are particularly important for attracting “interested but concerned” cyclists—those who are hesitant about biking due to safety concerns. Research shows that most people feel safer and are more inclined to ride when protected lanes are available, highlighting their importance in communities looking to increase ridership across various age groups and abilities.

### Should a Safer Bicycle Facility be Prioritized?

For each street in question, answer the prompts below. Total the results of each prompt to estimate how high priority a safer bicycle facility on that street may be.

FIGURE 37. FACILITY PRIORITY MATRIX

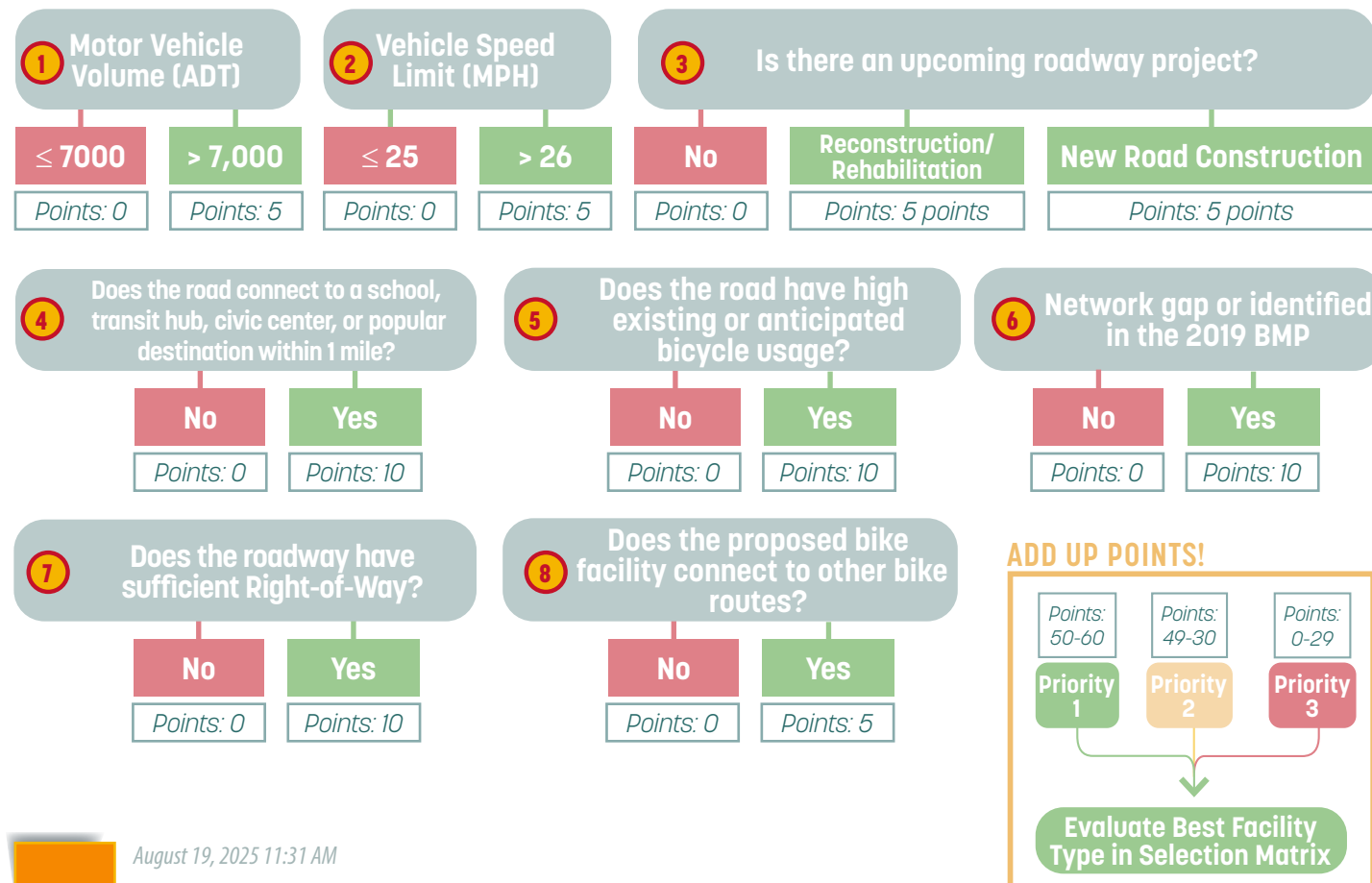

## FACILITY TYPE SELECTION MATRIX

After going through the prioritization matrix to determine the level of priority for a particular street for safer bicycle facilities, the next step is selecting the appropriate facility type. The following matrix guides the selection of the most suitable types of bicycle facilities for different areas and conditions within Santa Fe. It evaluates options like flexible delineators, on-street parking, planters, curbs stops, raised medians, and raised bike lanes, considering factors such as roadway type, traffic volume, speed limits, available street width, and surrounding context. This guide aids in determining which bike facility best fits specific environments, from rural and suburban areas to the Santa Fe urban core, ensuring safety, comfort, and aesthetic harmony with the local streetscape.

FIGURE 38. FACILITY TYPE SELECTION MATRIX

	Flex Posts	Bollards	On-Street Parking	Planters	Curb Stops	Raised Median	Raised Bike Lane
<b>Roadway Type</b>							
Major Arterial (6 Lane)						✓	✓
Minor Arterial (4 Lane)		✓			✓	✓	✓
Minor Arterial (2 Lane)	✓	✓	✓		✓		
Collector	✓	✓	✓	✓	✓		
<b>Average Daily Traffic (ADT) *Only appropriate on roads with speed limits of 25 mph or below</b>							
7k - 10k	✓	✓	*	✓			
Greater than 10k					✓	✓	✓
<b>Posted Speed (Miles per Hour)</b>							
0-25		✓	✓				
25-35	✓	✓		✓	✓		
>35						✓	✓
<b>Recommended widths for one-way facilities on both sides of the street (lane + buffer).</b>							
12'8"						✓	
14'	✓	✓			✓	✓	✓
16'	✓	✓	✓		✓	✓	✓
18'	✓	✓	✓	✓	✓	✓	✓

FIGURE: 38. FACILITY TYPE SELECTION MATRIX

	Flex Posts	Ballards	On-Street Parking	Planters	Curb Stops	Raised Median	Raised Bike Lane
Recommended widths for a two-way, one-side street facility (lane + buffer)							
13'4"						✓	
14'	✓	✓			✓	✓	✓
15'	✓	✓	✓		✓	✓	✓
16'	✓	✓	✓	✓	✓	✓	✓
Context Classification							
Rural	✓				✓	✓	
Rural Town	✓	✓			✓	✓	✓
Suburban	✓	✓	✓	✓	✓	✓	✓
Urban	✓	✓	✓	✓	✓	✓	✓
Santa Fe Core		✓	✓	✓	✓		✓
Aesthetics							
Provides room for landscaping.				✓		✓	✓
Variety of options for shapes, colors, and materials.		✓		✓	✓	✓	✓
Provides surfaces that can be decoratively painted or wrapped.		✓		✓	✓	✓	✓
Comfort							
Lower comfort near high vehicle travel speeds.	✓		✓	✓	✓		
Moderate comfort due to higher separation from traffic.		✓	✓	✓	✓		
High comfort due to highest separation from traffic.						✓	✓

## CONFLICT RESOLUTION

Safer bicycle facilities provide essential safety benefits but require targeted design strategies to address potential conflict points. Our recommendations include high-visibility markings, setback crossings, dedicated signals, raised crossings, and buffer zones to promote smooth and safe interactions among cyclists, drivers, pedestrians, and transit users. Implementing these measures will enhance the safety, functionality, and appeal of safer bicycle facilities in urban settings.

### Intersections and Driveways

#### CONFLICT:

Intersections and driveways where vehicles turn across the bike lane pose a risk to cyclists as drivers may only sometimes see or yield to cyclists in time.

#### STRATEGIES:

- ✓ **Dedicated Signal Phasing:** Separate traffic signal phases for cyclists and turning vehicles can prevent simultaneous movements, reducing conflicts.
- ✓ **Green Paint, High-Visibility Markings, and Signage:** Marking bike lanes with green paint or other high-visibility treatments and signage at intersections and driveways helps alert drivers to the presence of cyclists.
- ✓ **Setback Crossings:** Setting back the bike lane crossing from the main intersection or driveway gives turning drivers more time to see and yield to cyclists.
- ✓ **Raised Crossings:** Slightly elevating the bike lane at crossings is a speed-calming measure for turning vehicles, encouraging them to slow down.

### Bus Stops and Transit Stations

#### CONFLICT:

When a bike lane passes in front of or behind a bus stop, conflicts can arise between cyclists and transit users boarding or exiting buses.

#### STRATEGIES:

- ✓ **Floating Bus Stops:** Positioning the bus stop on an island between the bike lane and vehicle lane allows

transit riders to board without crossing the bike lane directly.

- ✓ **Yield Markings and Signage:** Marked crossings and yield signs at bike lane intersections near bus stops can improve awareness among cyclists and transit users.
- ✓ **Dedicated Bike Signals:** Signalized crossings for cyclists near bus stops can help organize traffic flow and reduce potential interactions.

### Parking and Loading Zones

#### CONFLICT:

Parked vehicles or loading zones adjacent to protected bike lanes can create “dooring” risks or situations where vehicles cross the bike lane to enter or exit the parking lane.

#### STRATEGIES:

- ✓ **Buffer Zones:** Installing a buffer between the bike lane and parking zone allows extra space for passengers to exit vehicles without obstructing cyclists.
- ✓ **Raised Bike Lanes:** Elevating the bike lane to curb level discourages vehicles from entering the bike lane and can further separate parked vehicles.
- ✓ **Parking Management:** Limiting or relocating parking near busy bike corridors can minimize vehicle-bicycle interactions.

# DESIGN STRATEGIES

Santa Fe's visual and cultural identity expresses itself through a rich and layered aesthetic. The region's distinctive landscapes, building materials, colors, and patterns are a testament to its history as a crossroads of cultures, drawing influences from Native American, Spanish Colonial, Mexican Folk, and American ranch traditions. This iconic and eclectic style offers an opportunity to inspire the design of bicycle facilities. Median and planter landscaping can reflect the high-desert environment. In contrast, materials for bollards, curb stops, median pavers, and planters can echo the region's traditional building elements, incorporating character-defining, cultural, and art elements. These facilities can also incorporate the area's characteristic colors and patterns, with the involvement of local artists to infuse authentic cultural expression into their design.



*Semiarid landscaping*



*Adobe and wood*



*Ironwork*



*Tinmithing and Artisinal Talavera*



*Ceramic and Terrocatta Tile*



*The Santa Fe County Courthouse*



*Santa Fe welcome sign on Highways 84 and 285*

## UNIQUE BICYCLE FACILITIES DESIGN ELEMENTS

The design of bicycle facilities often prioritize cost over aesthetics, but there is ample opportunity to incorporate thoughtful design choices. Landscaping, materials for protective elements and pavement, and decorative paint and patterns all offer room for stylistic expression. Across the United States, some cities have demonstrated how bicycle facilities can be customized to reflect local character. Similarly, Santa Fe's distinctive style could be integrated into its bike infrastructure, showcasing its unique aesthetic. The images below highlight a few examples of more creative bicycle facilities.



*Gibbs Street, Rockville, MD*



## LANDSCAPE BUFFERS

The arid landscape of New Mexico and Santa Fe is a striking tapestry of high-altitude desert, rugged terrain, and vibrant ecosystems uniquely adapted to this climate. This region's natural palette is defined by hardy, drought-tolerant plants that survive and thrive in these challenging conditions.

Native landscape buffers could enhance bicycle facilities by combining safety with environmental and aesthetic benefits. They support habitat, sequester carbon, and add visual appeal through the use of native and adapted plant species. Designed with permeable soils and vegetation, these buffers can function as green stormwater infrastructure, capturing and filtering runoff, reducing pollutants, and replenishing groundwater supplies. Incorporating features like bioswales, rain gardens, and berms, they effectively manage stormwater while blending with natural surroundings, softening urban edges, and fostering biodiversity.



A landscaped median in Russellville, AR.



Planter Protected Bike Lanes in Minneapolis



Arid environment-appropriate landscaping can also be effectively integrated into bicycle facilities in Santa Fe, drawing inspiration from examples like those in Albuquerque.

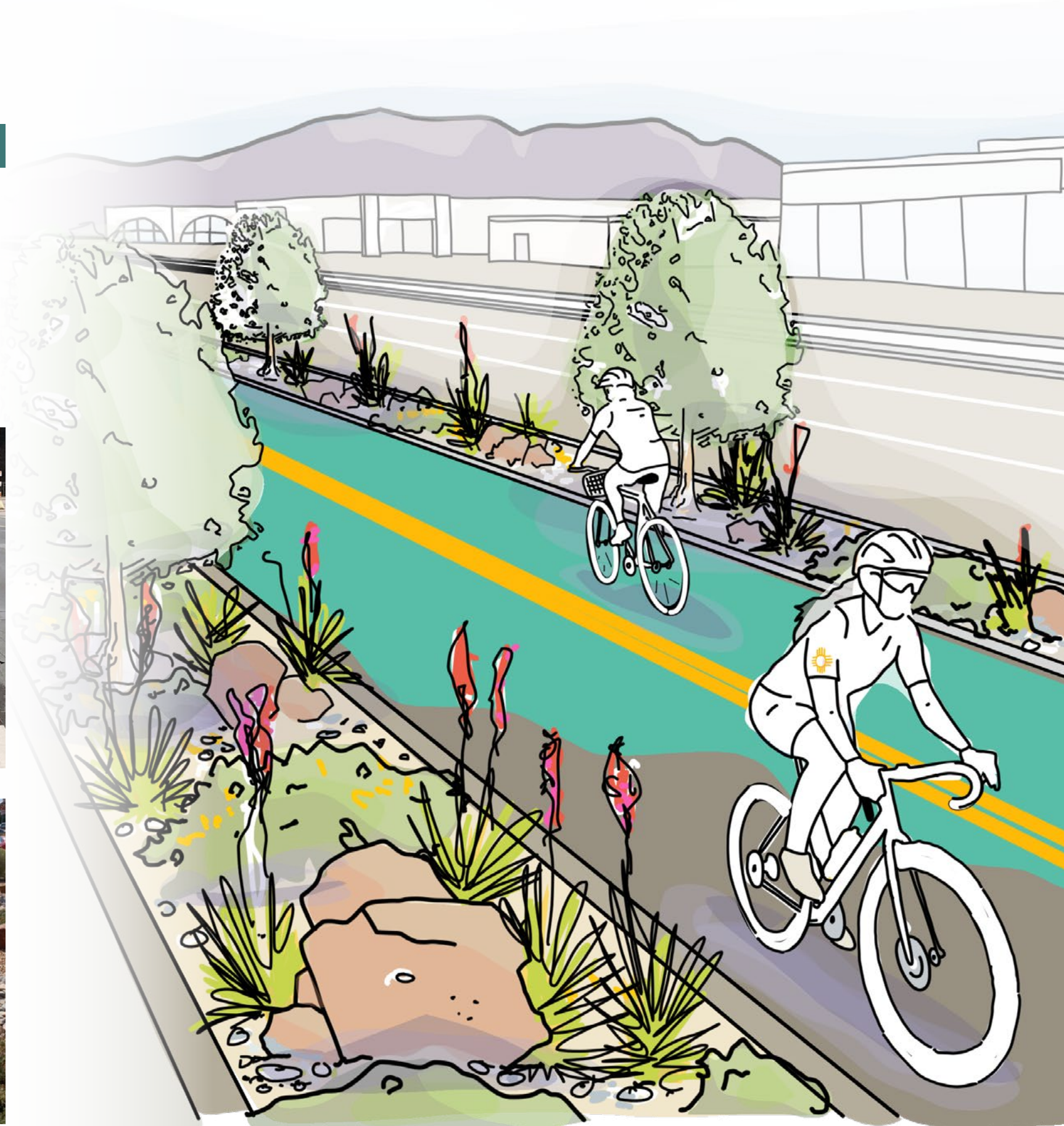

Native landscape buffers enhance visual appeal, provide meaningful separation between cyclists and cars, function as stormwater infrastructure, and create valuable wildlife habitat.

## MATERIALS

Bicycle facilities in Santa Fe can emulate traditional building materials like adobe while incorporating durable materials such as stucco, ceramic tile, and cast iron. These elements can be thoughtfully integrated into various facility types to reflect the region's architectural heritage. Bollards, planters, and concrete curbs can be designed with materials that complement this style, while raised medians or elevated bicycle facilities could feature pavers or surface treatments inspired by Santa Fe's traditional aesthetic.



While simple plastic "flexible delineators" are commonly used in bicycle facilities, there are many more stylish bollard options that align with Santa Fe's aesthetic.



For curb stops or other low-lying barriers or walls, a wide variety of styles are available that complement Santa Fe's unique aesthetic.



Simple cuboid planters offer plenty of opportunities for selecting materials and patterns.



Surface treatments or paver materials that align with Santa Fe's style can be used for median-protected and raised bicycle facilities.

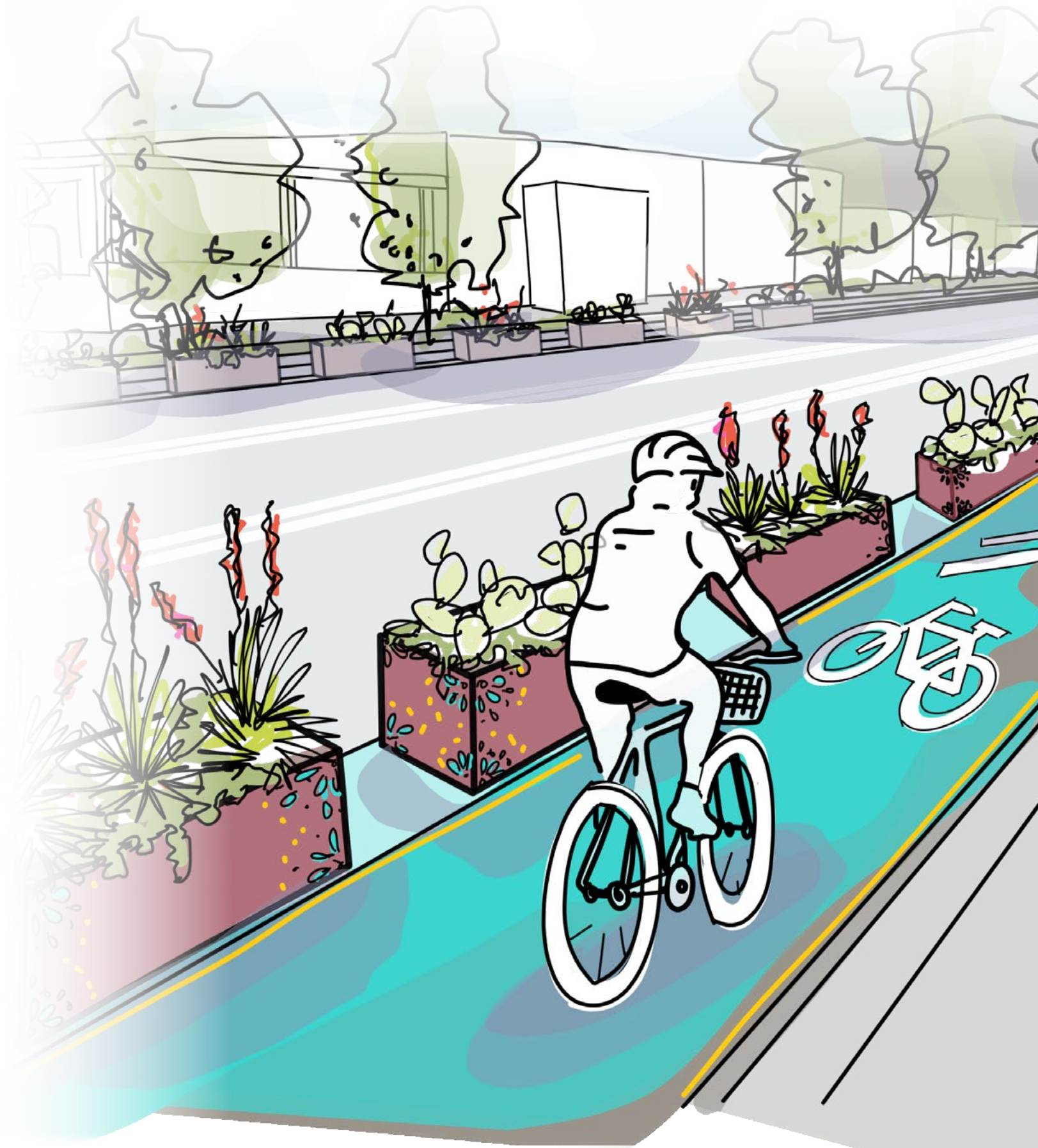

Planters featuring perforated steel design elements can serve as protective barriers while incorporating distinctive Santa Fe design motifs.

## PAINT AND PATTERNS

Paint, patterns, and colors are central to Santa Fe and New Mexican design, reflecting the region’s cultural heritage and natural surroundings. The style features an earth-tone palette inspired by the desert landscape, with soft browns, tans, ochres, and warm yellows as backdrops, accented by vibrant turquoise, deep blues, subtle greens, and rust reds. Geometric patterns from Native American art and weaving, along with Spanish Colonial floral and vine motifs, appear in tiles, murals, and carved woodwork. Bold, hand-painted tiles and mosaics commonly enhance staircases, fountains, and public spaces. Incorporating these elements into bicycle facilities, such as through painted barriers or medians, can enhance their aesthetic appeal. Engaging local artists and the community in the process can further enrich the designs.



ATECH Pastel Bollards



Painted planters in Perth, Australia



StrongSoft by Cat Willett - NYC DOT



Tiled streetscape in Chicago



Painted buffer with symbols



Gibbs Street, Rockville, MD



Alphabet City by Elizabeth Hamby - NYC DOT



Painted curb stops featuring Native American patterns and vibrant turquoise pavement are relatively inexpensive options to incorporate a unique Santa Fe design element into safer bike facilities.



**SANTA FE MPO**  
**DESIGNING FOR SAFER CYCLING**

